

# Building for High Wind Resistance in Light-Frame Wood Construction

**DESIGN GUIDE**





## Meeting the Challenge of High Wind Design

Designing a structure to withstand the devastating forces of tornadoes is one of the greatest challenges a builder can face. There is a common myth that all tornadoes are so strong that structural failure is imminent, no matter how well a building is constructed. The fact is, weaker tornadoes rated as EF-0, EF-1 and EF-2 by the National Weather Service statistically comprise 95 percent of all tornadoes. A home that is carefully constructed, in accordance with current building codes, can withstand these smaller, less violent storms.

Stronger tornadoes rating EF-3, EF-4 and EF-5 are much less common. While it is more difficult for homes to survive these storms, good design details can make a difference, particularly when the structure is located along the outer reaches of the area influenced by the vortex of the storm.

The design and construction recommendations in this guide from APA contribute to improved overall performance in the structural shell and focus on good connection details to tie together exterior walls, roofs and floors. *Some of these design recommendations exceed the minimum code requirements and typical APA recommendations.* These recommendations are intended for new construction only, although the principles may be appropriate for retrofit applications. The recommendations in this publication may not be appropriate for hurricane-prone regions. In those regions, local building code requirements must be followed.

Whether caused by a tornado or severe wind storm, high wind forces follow the load path of a structure. Good connections that tie the floor, walls and roof together provide continuity in the load path and more reliable building performance.

FIGURE 1

TIPS FOR IMPROVING TORNADO RESISTANCE OF LIGHT-FRAME WOOD CONSTRUCTION

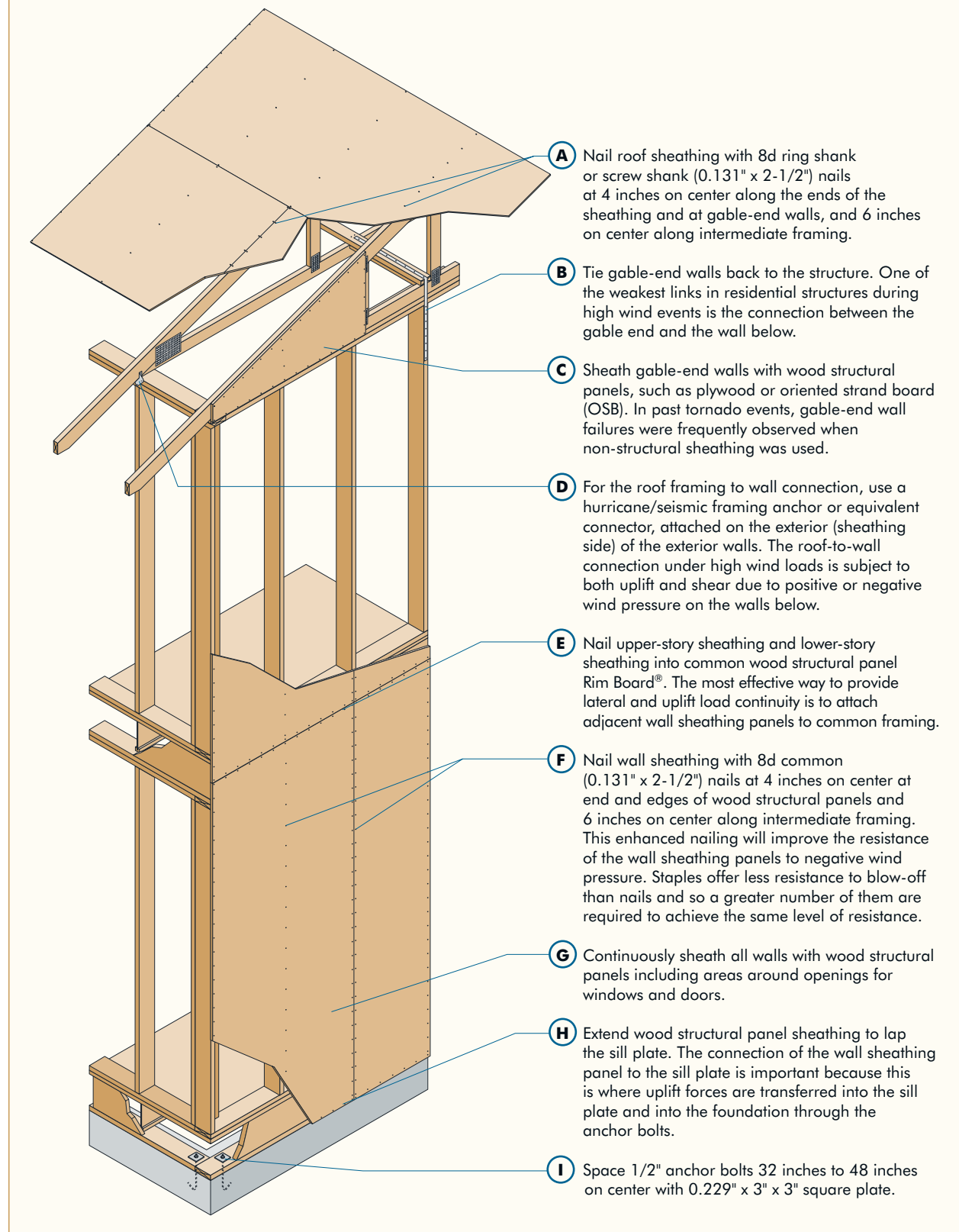

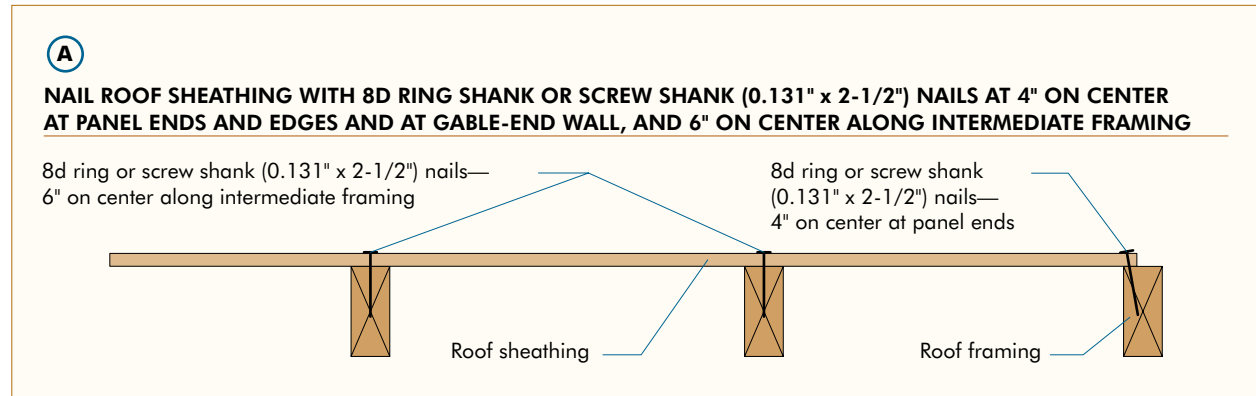

This installation shown above will greatly increase the wind resistance of the roof sheathing panels. It is important to note that the gable-end wall forms part of the perimeter of the roof diaphragm and the 4-inches on-center panel edge nailing must be applied at these locations. Lack of adequate nailing at this location may cause the loss of roof sheathing during high wind events.

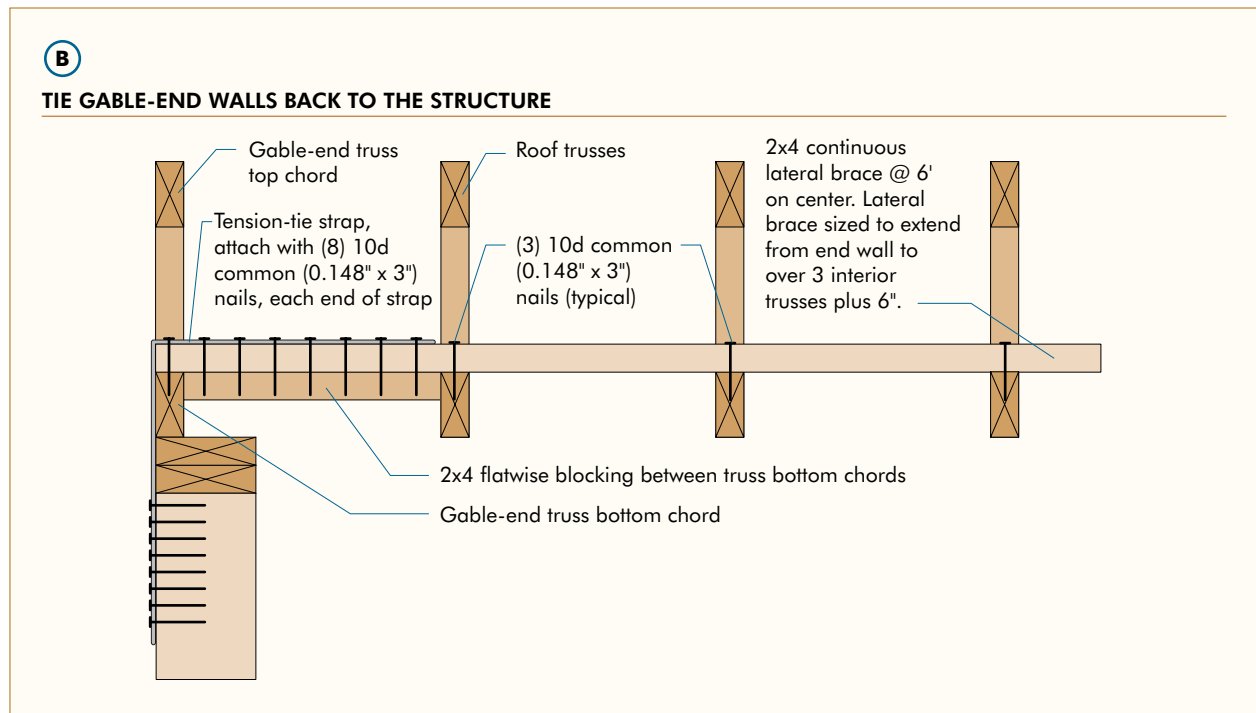

One of the weakest links in residential structures during high wind events is the connection between the gable end and the wall below. The prescriptive codes provide no guidance on how to properly attach these two important elements, and failures at this joint are, unfortunately, quite common. Construction details that have been developed to properly secure and tie back a gable end may be used. (Detail based on *Standard for Hurricane Resistant Residential Construction*, SSTD 10-93 Section 306.4.2.)

**C**

**SHEATH GABLE-END WALLS WITH WOOD STRUCTURAL PANELS, SUCH AS PLYWOOD OR ORIENTED STRAND BOARD (OSB)**

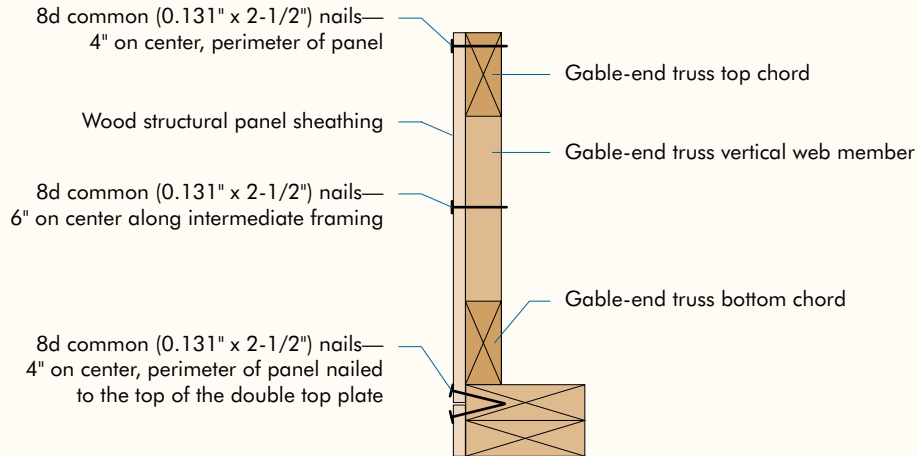

Gable-end wall failures are frequently observed when non-structural sheathing is used. Most non-structural foam sheathing materials are required to be used in conjunction with gypsum wall board inside of the house, which is frequently neglected in the construction of gable-end walls. The easiest way to avoid the need of installing interior gypsum at the gable-end walls is to use wood structural panel sheathing on the exterior. Note that gable-end sheathing and wall sheathing are both nailed to common framing.

**D**

**ROOF FRAMING TO WALL CONNECTION WITH HURRICANE/ SEISMIC FRAMING ANCHOR OR EQUIVALENT CONNECTOR ATTACHED ON SHEATHING SIDE OF THE EXTERIOR WALLS**

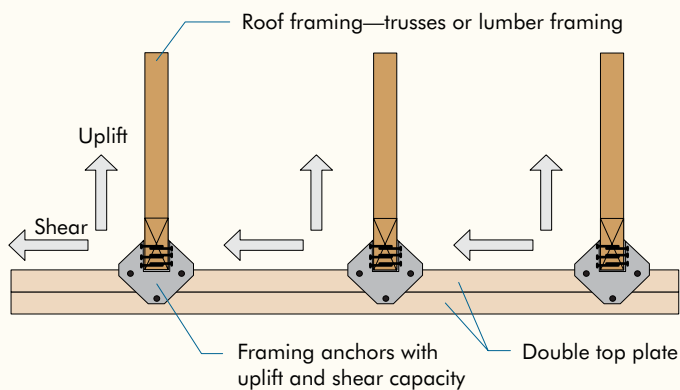

The roof-to-wall connection under high wind loads is subject to uplift and shear in either suction or pressure loads. A large number of framing anchor systems have been developed that can make this complicated connection as simple as putting in a nail at each hole. If raised heel trusses are used, the wall sheathing may be designed to overlap the top plates and truss heels to provide the uplift resistance required by the roof-to-wall connection. See *APA System Report SR-103* for details and limitations of using raised heel trusses to resist uplift forces.

**E**

**NAIL OFF UPPER STORY AND LOWER STORY SHEATHING INTO COMMON WOOD STRUCTURAL PANEL RIM BOARD®**

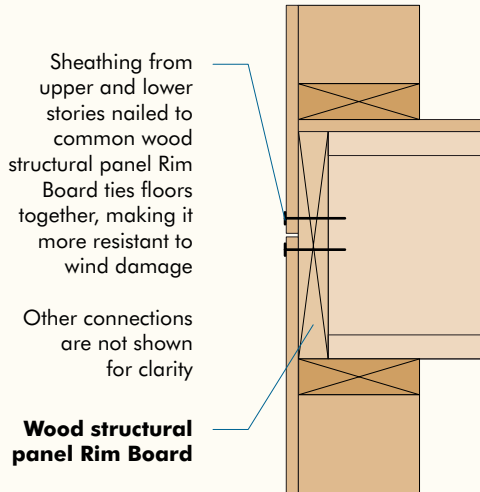

The most effective way to provide lateral and, in some cases, uplift load continuity is to attach adjacent wood structural panel wall sheathing over common framing. Engineered Rim Board® can be used at this common framing member to ensure shear and uplift continuity, which eliminates the need for horizontal blocking. Because it is at least 9-1/2 inches in depth, the Rim Board makes an excellent “target” for mating adjacent panels. This makes it easier to hit the framing when nailing the panel sheathing to the framing—a step that is complicated when mating two panels over the common 2x framing member while maintaining a 1/8-inch spacing between panels, and a 3/8-inch edge distance from the nail to the edge of the panel. Metal strap anchors designed for use around windows and doors may also be used as an alternative detail. For designed applications, additional information is available in *APA Data File: Shear Transfer at Engineered Wood Floors, Form Y250*.

**F**

**NAIL WALL SHEATHING WITH 8D COMMON (0.131" X 2-1/2") NAILS AT 4" ON CENTER IN THE BOUNDARY OF WOOD STRUCTURAL PANEL WALL SHEATHING AND 6" ON CENTER IN THE INTERMEDIATE STUDS**

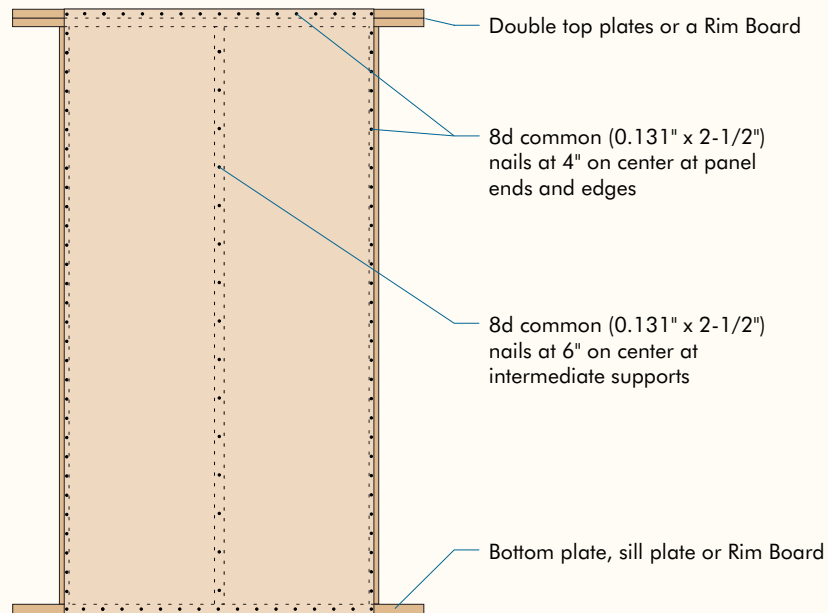

The installation shown above will increase the wind resistance of the wall sheathing panels, as compared to the minimum nailing requirements specified in the code.

**G**

**SHEATH ALL WALLS WITH WOOD STRUCTURAL PANELS**

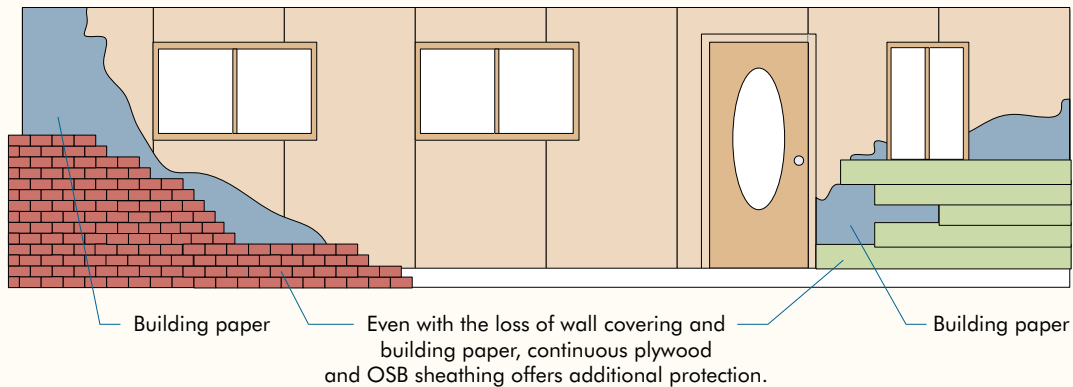

A solid plywood or OSB box is created when the roof and walls, properly attached, are completely sheathed. All of the wall needs protection from high wind and wind-driven debris, not just the bracing panels at corners and at intervals along the length of a wall. The minute the siding is blown off the wall, the remainder of the wall left behind must be able to protect the contents of the structure from the wind and rain by itself. Buildings that are continuously sheathed with wood structural panels have an additional layer of protection if siding is lost or brick veneer collapses during high wind events. In addition, if there is not structural panel sheathing attached to the sill plate in the area of the anchor bolt, its hold-down capacity is not transferred to the structure above.

**H**

**EXTEND WOOD STRUCTURAL PANEL SHEATHING AT BOTTOM WALL TO SILL PLATE INTERSECTION**

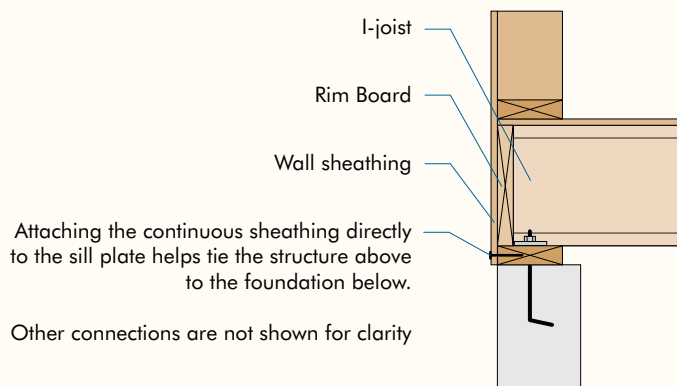

The connection of the wall sheathing panel to the sill plate is extremely important because this is the connection by which the hold-down capacity of the sill plate anchor bolting is distributed into the structure above. At this location, the panel can overlap the sill plate by the full 1-1/2 inches of the sill plate depth. It is wise to use all of this depth as it permits the use of nail-to-edge distances of up to 3/4 inch, yielding the maximum possible uplift capacity of the nailed joint. See **Detail F** for nailing recommendations.



**SPACE 1/2" ANCHOR BOLTS 32" TO 48" ON CENTER WITH 0.229" x 3" x 3" SLOTTED SQUARE PLATE WASHERS AT THE WALL TO SILL PLATE INTERSECTION**

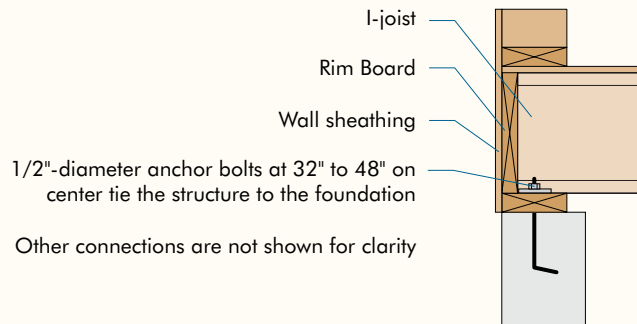

Much of the structural damage that occurs in wind storms is the result of the walls being lifted or pushed off of the foundation. In some cases, damage is due to the use of bottom plates nailed to the concrete foundation. These connections perform poorly under high wind loads. Another source of damage is the use of no washers or standard cut washers under the anchor bolt nuts. During high wind uplift, the nuts can pull through the bottom plates and, like the nailed bottom plates, do not provide the required resistance to keep the walls anchored. The IRC requires a minimum of 1/2-inch-diameter anchor bolt at 72 inches on center spacing for homes subjected to wind speeds up to  $V_{asd}=110$  mph ( $V_{ult}=140$  mph). However, the use of 1/2-inch-diameter anchor bolts spaced 32 inches to 48 inches on center with 0.229 inches x 3 inches x 3 inches slotted square plate washers will greatly improve the resistance to high wind. The slotted square plate washer should be placed as close to the sheathing side of the wall as possible.



## OTHER CONSIDERATIONS:

The details presented in this guide offer relatively simple ways to increase the wind performance of a structure. There are a number of additional topics that the builder/homeowner can consider during the planning or construction phase of the project:

**Protection of large openings**—As far as wind damage is concerned, large openings in walls such as picture windows, sliding glass doors and garage doors are extremely vulnerable to damage in high wind events. Because their dimensions are large, the total force on such windows and doors is also extremely large. They also make for big targets for wind-born debris. Breaching of these elements can be especially damaging to the structure because the size of the opening can lead to pressurization of the entire building, which can cause failures of other portions of the structure that would be otherwise secure, not to mention the potential for water damage. For these reasons, a builder or homeowner may want to consider windows and doors that are rated for high wind and impact damage. Carefully follow manufacturers' installation requirements for the windows and doors.

**Basements and Safe Rooms**—The provisions covered in this guide are meant to develop a stronger, more wind-resistant structure. While a stronger structure is certainly safer for the occupants, consider a design that also includes a full or partial basement or safe room or a combination of both.

**Hip roofs**—While they will not appeal to everyone's aesthetic sense, hip roofs have a long history of superior performance in high wind events when compared to gable-end roofs.

## About APA

APA is a nonprofit trade association of and for structural wood panel, glulam timber, wood I-joist, structural composite lumber and other engineered wood product manufacturers. Based in Tacoma, Washington, APA represents approximately 172 mills throughout North America, ranging from small, independently owned and operated companies to large integrated corporations.

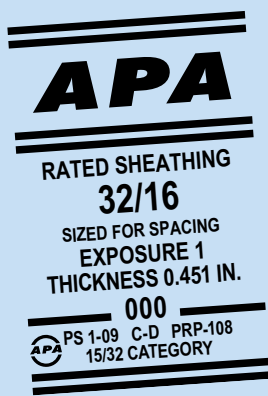

Always insist on panels bearing the mark of quality—the APA trademark. Your APA panel purchase is not only your highest possible assurance of product quality, but an investment in the many trade services that APA provides on your behalf. The Association's trademark appears only on products manufactured by member mills and is the manufacturer's assurance that the product conforms to the standard shown on the trademark. That standard may be an APA performance standard, the Voluntary Product Standard PS 1-09 for Structural Plywood or Voluntary Product Standard PS 2-10, Performance Standard for Wood-Based Structural-Use Panels. Panel quality of all APA trademarked products is subject to verification through APA audit.

## Building for High Wind Resistance in Light-Frame Wood Construction

We have field representatives in many major U.S. cities and in Canada who can help answer questions involving APA trademarked products. For additional assistance in specifying engineered wood products, contact us:

### **APA HEADQUARTERS**

7011 So. 19th St. ■ Tacoma, Washington 98466  
(253) 565-6600 ■ Fax: (253) 565-7265

### **PRODUCT SUPPORT HELP DESK**

(253) 620-7400 ■ [help@apawood.org](mailto:help@apawood.org)

### **DISCLAIMER**

*The information contained herein is based on APA – The Engineered Wood Association’s continuing programs of laboratory testing, product research, and comprehensive field experience. Neither APA, nor its members make any warranty, expressed or implied, or assume any legal liability or responsibility for the use, application of, and/or reference to opinions, findings, conclusions, or recommendations included in this publication. Consult your local jurisdiction or design professional to assure compliance with code, construction, and performance requirements. Because APA has no control over quality of workmanship or the conditions under which engineered wood products are used, it cannot accept responsibility for product performance or designs as actually constructed.*

Form No. M310E/Revised August 2018



REPRESENTING THE ENGINEERED WOOD INDUSTRY