

## CHAPTER 3 BUILDINGS WITH WOOD-FRAMED EXTERIOR WALLS

### 301 SCOPE

This chapter prescribes construction requirements for buildings where all exterior walls above the foundation are wood framed and where the building meets the parameters and requirements of Chapter 1. Except as otherwise noted herein, interior walls and partitions may be of any construction permitted by the code.

Where figures show masonry units for walls, concrete walls shall be permitted. Where the nominal dimension of 8 inches thick are used for masonry units, the equivalent dimensions for concrete walls shall be permitted to be 7.5 inches.

### 302 GENERAL

#### 302.1 FASTENERS AND CONNECTORS

This standard contains figures showing connectors. The connectors are shown for illustrative purposes only. The illustration of the connectors is not intended to endorse any connector manufacturer. In order to choose the appropriate connector please check with the connector manufacturer.

**302.1.1** A continuous load path between footings, foundation walls, floors, studs, and roof framing shall be provided.

**302.1.2** Approved connectors, anchors, and other fastening devices not included in the Standard Building Code shall be installed in accordance with the manufacturer's recommendations. Where fasteners are not otherwise specified in this standard, fasteners shall be provided in accordance with Table 2306.1 of the Standard Building Code (see Appendix E). Nails, screws, or bolts shall be able to resist the forces specified in this Standard. Screws shall comply with requirements contained in the National Design Specifications for Wood Construction.

**302.1.3** Metal plates, connectors, screws, bolts and nails exposed directly to the weather or subject to salt corrosion in coastal areas, as determined by the building official, shall be stainless steel, hot dipped galvanized after the fastener or connector is fabricated to form a zinc coating not less than 1 oz per sq ft, or hot dipped galvanized with a minimum coating of 1.8 oz per sq ft of steel meeting the requirements of ASTM A 90 Triple Spot Test.

**302.1.4** Unless otherwise stated, sizes given for nails are common wire nails (See Table 12.3B of the American Forest and Paper Association's (AF&PA) National Design Specifications for Wood Construction).

### 303 FOOTINGS AND FOUNDATIONS

#### 303.1 GENERAL

**303.1.1 Design:** All exterior walls, bearing walls, interior shearwalls, columns, and piers shall be supported on concrete footings, piles, or other approved structural systems which shall be of sufficient design to support safely the loads imposed as determined from the character of the soil (Refer to Figures 303A-303F for typical foundation details). Reinforcement shown is for uplift forces only. Provide other reinforcement as required in chapters 18 and 19 of the Standard Building Code.

**303.1.2 Masonry Units:** Masonry units shall be hollow or solid concrete units in accordance with ASTM C 90 or C 145 and shall have a minimum net area compressive strength of 1900 psi. Masonry units shall be hollow or solid clay units in accordance with ASTM C 62, C 216 or C 652 and shall have a minimum net area compressive strength of 4400 psi.

**303.1.3 Mortar:** Mortar shall be either Type M or S in accordance with ASTM C 270.

**303.1.4 Grout:** Grout shall have a maximum coarse aggregate size of 3/8 inch placed at an 8 to 11 inch slump and have a minimum specified compressive strength of 2,000 psi at 28 days when tested in accordance with ASTM C 1019, or shall be in accordance with ASTM C 476.

#### 303.1.5 Concrete

**303.1.5.1** Concrete shall have a minimum specified compressive strength of 2500 psi at 28 days.

**303.1.5.2** Concrete containing reinforcement that will be exposed to chlorides for deicing chemicals, salts, salt water, brackish water, sea water, or spray from these sources shall meet the durability requirements in Section 1904 of the 1994 Standard Building Code (SBC).

**303.1.6 Reinforcing Steel:** Reinforcing Steel shall be minimum Grade 40 and identified in accordance with ASTM A 615, A 616, A 617, or A 706.

**303.1.7 Metal Accessories:** Joint reinforcement, anchors, ties, and wire fabric shall conform to the following standards:

1. ASTM A 82 for joint reinforcement and wire anchors and ties.
2. ASTM A 36 for plate, headed and bent bar anchors.
3. ASTM A 366 for sheet metal anchors and ties.

Metal accessories for use in exterior wall construction and not directly exposed to the weather shall be galvanized in accordance with ASTM A 153, Class B-2. Metal accessories for use in interior wall construction shall be mill galvanized in accordance with ASTM A 641, Class 1.

### **303.1.8 Mortar Joints and Reinforcement.**

**303.1.8.1** All mortar joints for hollow unit masonry shall extend the full width of face shells. Mortar joints for solid masonry shall be full head and bed joints.

**303.1.8.2** Bed joints shall be 3/8 inch ( $\pm$  1/8 inch) thick. Head joints shall be 3/8 inch (+ 3/8 inch or -1/4 inch) thick.

**303.1.8.3** The bed joint of the starting course placed over footings shall be permitted to vary in thickness from a minimum of 1/4 inch to a maximum of 3/4 inch.

**303.1.8.4** Masonry walls shall be running bond or stack bond construction. Walls of stack bond construction, in addition to required vertical reinforcement, shall be provided with a minimum of 9 gage horizontal joint reinforcement placed in bed joints not more than 16 inches on center.

**303.1.8.5** Longitudinal wires of joint reinforcement shall be fully embedded in mortar or grout with a minimum cover of 5/8 inch when exposed to earth or weather and 1/2 inch when not exposed to earth or weather.

### **303.1.9 Cover Over Reinforcement.**

**303.1.9.1** For foundations, minimum concrete cover over reinforcing bars shall be:

1. 3 inches in foundations where the concrete is cast against and permanently in contact with the earth.
2. 1 1/2 inches for No. 5 and smaller bars and 2 inches for No. 6 and larger bars where concrete is formed and will be exposed to the earth or weather.

In narrow footings where insufficient width is available to accommodate a standard 90 degree hook and provide the required concrete cover, the hook shall be rotated in the horizontal direction until the required concrete cover is achieved.

**303.1.9.2** For concrete elements where concrete is not exposed to weather, the minimum concrete cover for reinforcing shall be 1 1/2 inches regardless of bar size.

**303.1.9.3** For concrete elements where concrete is exposed to weather, the minimum concrete cover for reinforcing shall be:

1. 1 1/2 inches for No. 5 bars and smaller.
2. 2 inches for No. 6 bars and larger.

**303.1.9.4** Reinforcing bars embedded in grouted masonry cells shall have a minimum clear distance of 1/4 inch for fine grout or 1/2 inch for coarse grout between reinforcing bars and any face of a cell.

**303.1.9.5** Reinforcing bars used in masonry walls shall have a masonry cover (including grout) not less than:

1. 2 inches for masonry units with face exposed to earth or weather.
2. 1 1/2 inch for masonry units not exposed to earth or weather.

## **303.2 STEMWALL FOUNDATIONS**

### **303.2.1 Footings.**

**303.2.1.1** Footings for stemwalls for a one-story or a two-story building shall be at least 20 inches wide by 10 inches thick and shall be reinforced with two No. 5 continuous bars.

**303.2.1.2** Footings shall be level or shall be stepped so that both top and bottom of such footings are level.

**303.2.2 Exterior Foundation Walls:** Exterior foundation walls shall extend no more than 3 ft above the finish grade and shall be constructed with minimum 8 inch concrete masonry units in accordance with Figures 303A, B, and C or shall be constructed with a minimum 6 inch hollow clay brick or minimum 3 inch solid clay brick and minimum 4 inch hollow concrete masonry unit in accordance with Figure 303D1, D2, or D3.

**303.2.2.1** Reinforcing for foundation walls illustrated in Figures 303A, B, and C shall comply with the following:

1. An 8x8 inch concrete or CMU bond beam with one No. 5 bar shall be used at the floor level. Reinforcing shall be continuous at corners by use of corner bars or bending; minimum lap is 25 inches.
2. Vertical reinforcement consisting of one No. 5 bar shall be used at 8 ft on center and shall terminate in the bond beam with a standard hook.
3. Footing dowel bars embedded a minimum of 6 inches into the footing shall be provided for all required vertical reinforcement. Dowels shall lap wall reinforcing a minimum of 25 inches.
4. All footing dowel bars shall have a standard 90 degree hook.

EXCEPTION: If uplift connectors are continuous from the exterior wall into the footing, vertical reinforcement is not required except at corners.

**303.2.2.2** Loads on foundation walls illustrated in Figures 303D1, D2 and D3 shall comply with the following:

1. The uplift force on each strap shall not exceed 1,680 lb.
2. For the foundation wall shown in Figure 303D1, the sum of the required shear capacities stated in Tables 304B1, 304B2, 307H1, and 307H2, as applicable, shall not exceed 421 plf.
3. For the foundation wall shown in Figure 303D2, the sum of the required shear capacities stated in Tables 304B1, 304B2, 307H1, and 307H2, as applicable, shall not exceed 389 plf.
4. For the foundation wall shown in Figure 303D3, the sum of the required shear capacities stated in Tables 304B1, 304B2, 307H1, and 307H2, as applicable, shall not exceed 307 plf.

**303.2.3 Sill Plate to Foundation Anchorage:** For the foundation system illustrated in Figures 303A, B and C, sill plates shall be anchored to the foundation system with anchor bolts having a minimum bolt diameter of 5/8 inch and 3"x3"x1/8" washers. A minimum of one anchor bolt shall be provided within 6 to 12 inches of each end of each plate. Anchor bolts shall have a minimum embedment of 7 inches in concrete or concrete/masonry foundations. Anchor bolts shall be located within 12 inches of corners and at spacings not exceeding 4 feet on center.

When uplift connectors are provided at every full length stud and are continuous from the exterior wall into the foundation wall, anchor bolt spacings may be increased to 6 feet on center for one story buildings. Standard washers may be used (See Table 303.2.3).

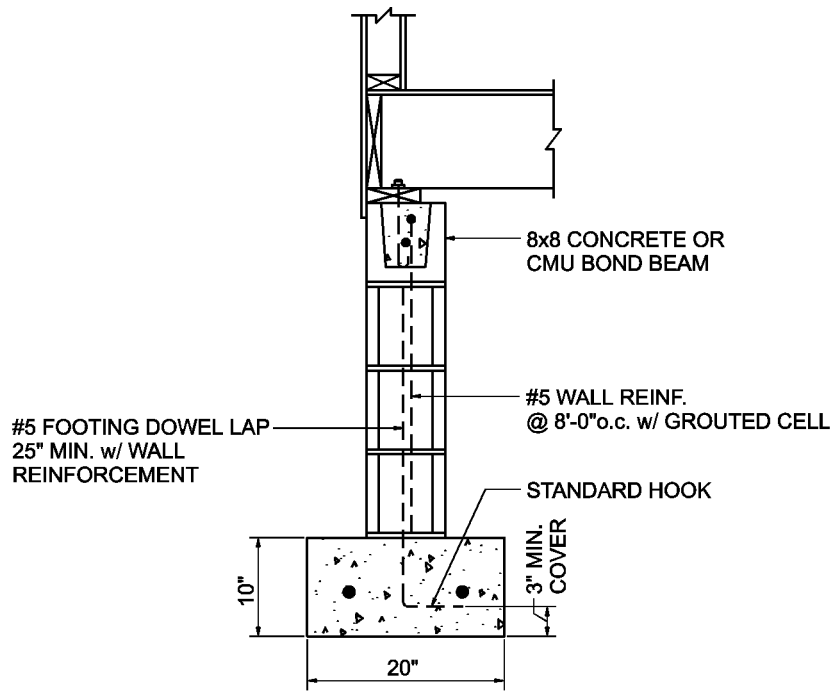
**TABLE 303.2.3  
SILL PLATE TO FOUNDATION ANCHORAGE**

		Fastest Mile Windspeed (mph)		
		90	100	110
Anchor Bolt Resisting	Foundation Supporting:	Maximum Anchor Bolt Spacing (ft)		
Lateral, Shear & Uplift Loads	1 Story	4	4	4
	2 Stories	4	4	4
Lateral & Shear Loads Only	1 Story	6	6	6
	2 Stories	4	4	4

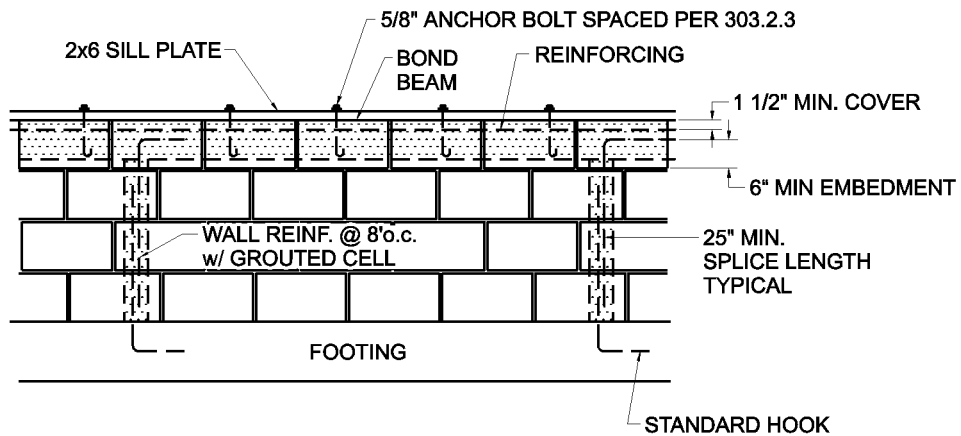
**303.2.3.1** For the foundation wall systems illustrated in Figures 303D1, D2, and D3, galvanized or stainless steel straps shall be nailed to a minimum 2x6 inch nominal rim joist with a minimum of nine 16d nails. Straps shall be a minimum of 2 1/16 inches in width and 12 gage in thickness. Straps shall be embedded into the concrete footing a minimum of 4 inches and shall have a minimum horizontal leg extension of 1 3/4 inches.

**303.2.3.2** Stemwall foundations with a slab-on-grade shall meet the wall to foundation anchorage requirements specified in 303.3.2. (See Figure 303G).

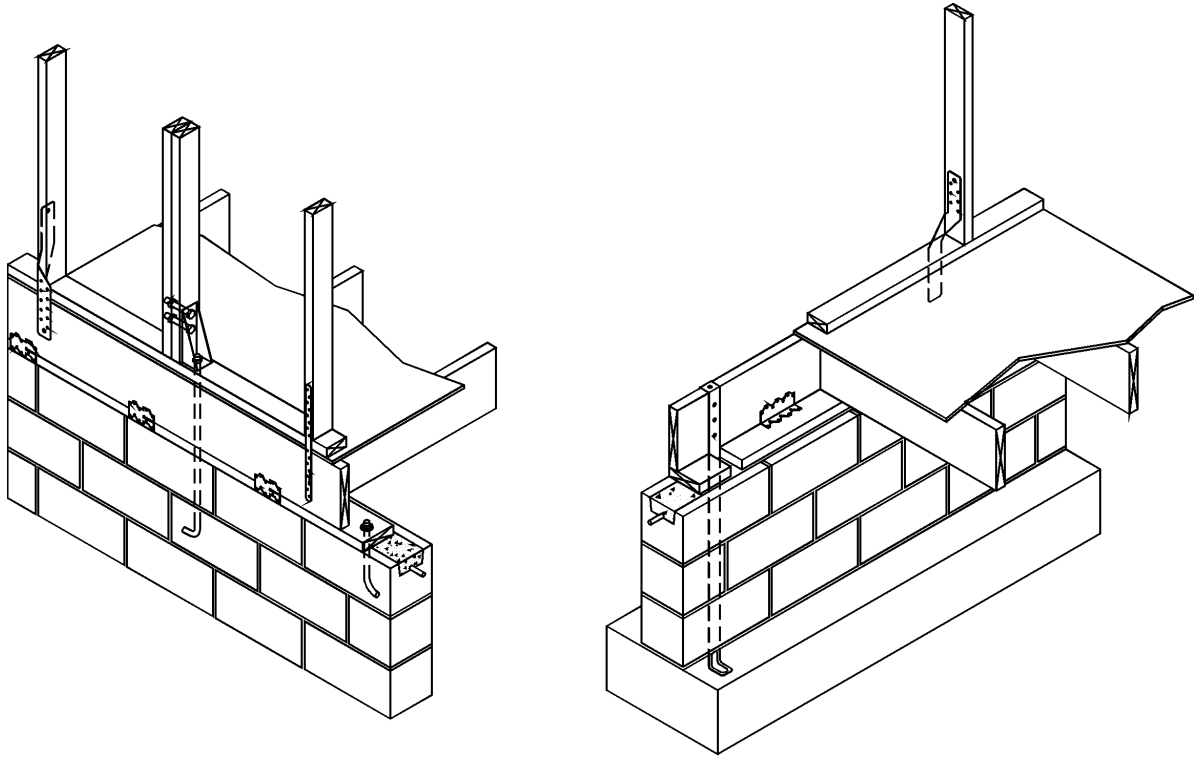
**303.2.4 Interior Foundation Walls:** Interior foundation walls shall be the same as for exterior walls except that vertical reinforcing is only required where walls subject to uplift or shear are supported. Interior monolithic slab-on-grade foundations may be used with exterior stemwall foundations.



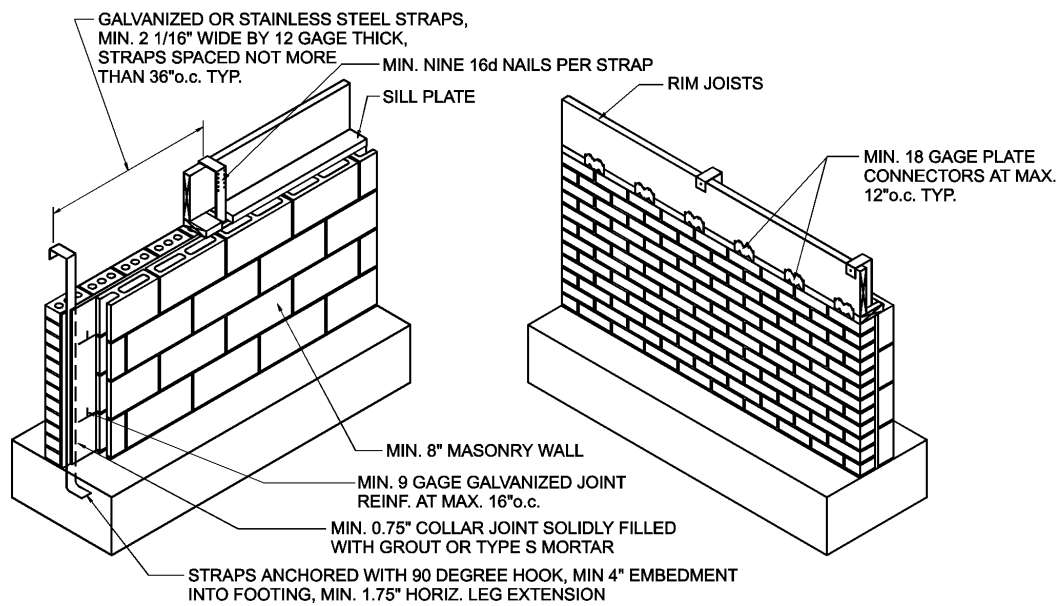
**FIGURE 303A**  
**WOOD FLOOR TO CONCRETE OR MASONRY STEMWALL**



**FIGURE 303B**  
**SILL PLATE TO STEMWALL CONTINUITY REINFORCEMENT**



**FIGURE 303C**  
**TYPICAL FOUNDATION TIE-DOWN METHOD**



**FIGURE 303D1, PART A**

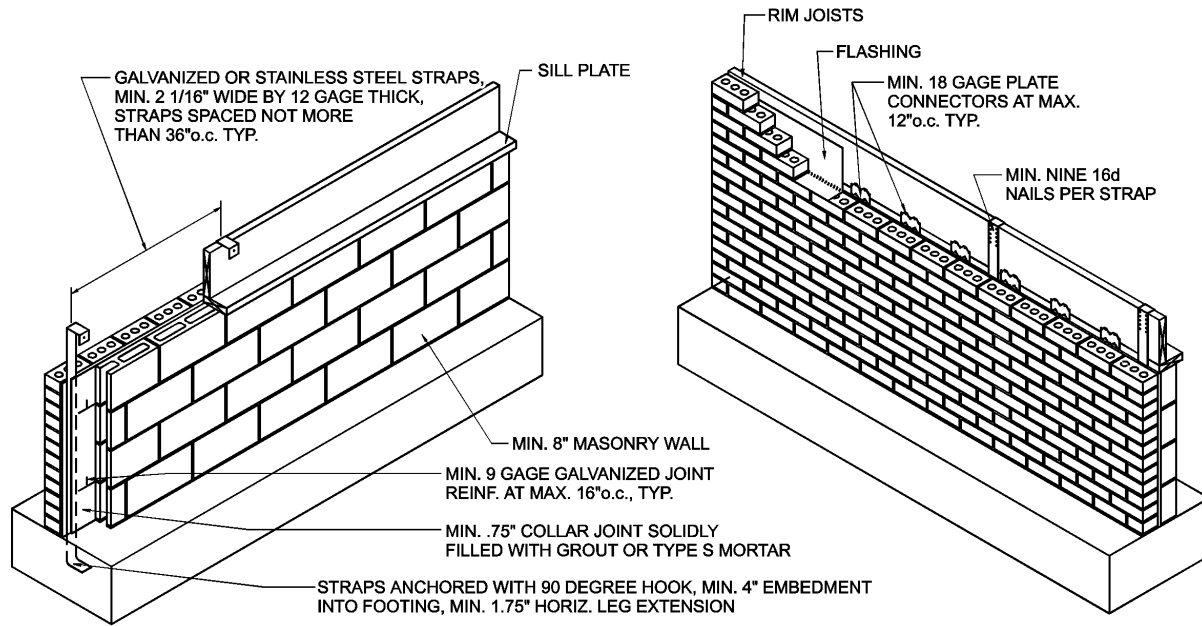


FIGURE 303D1, PART B

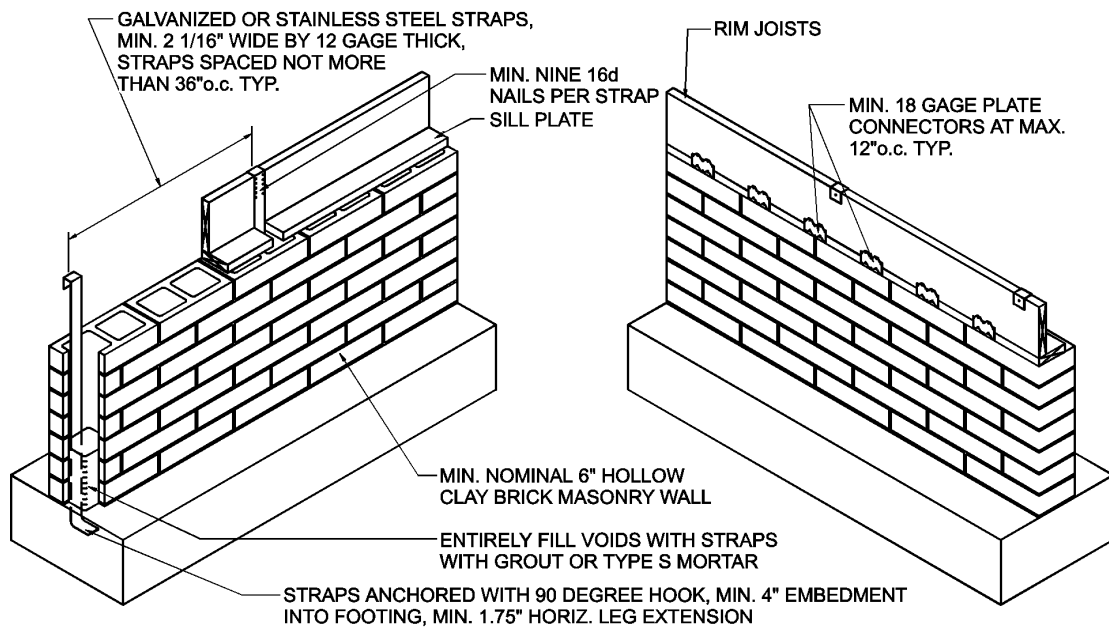


FIGURE 303D2

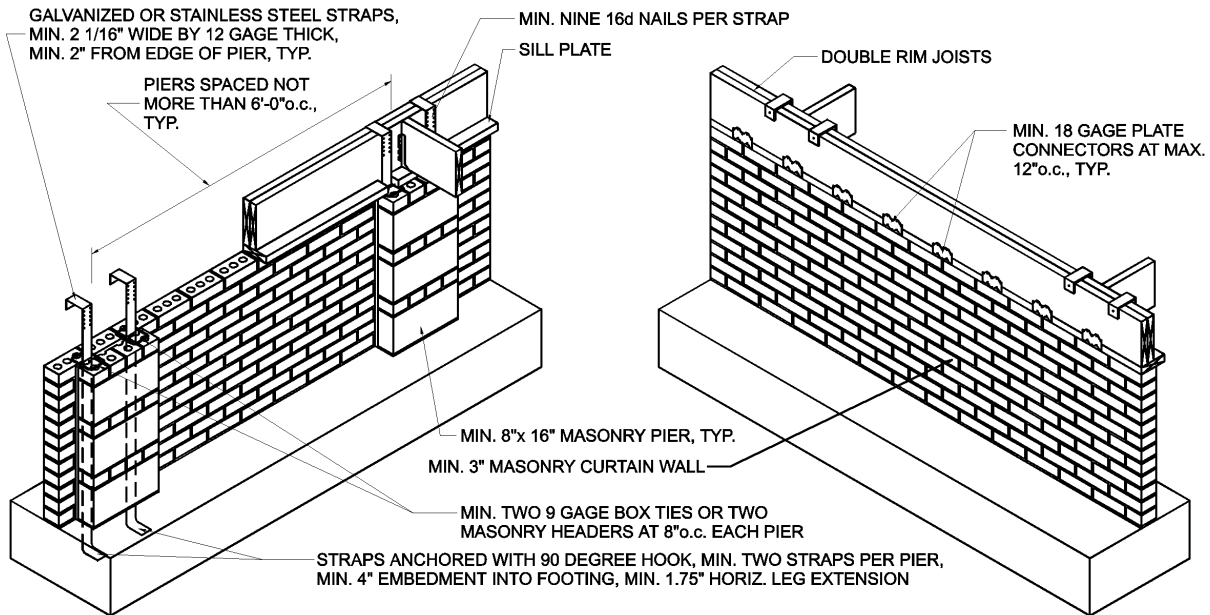


FIGURE 303D3, PART A

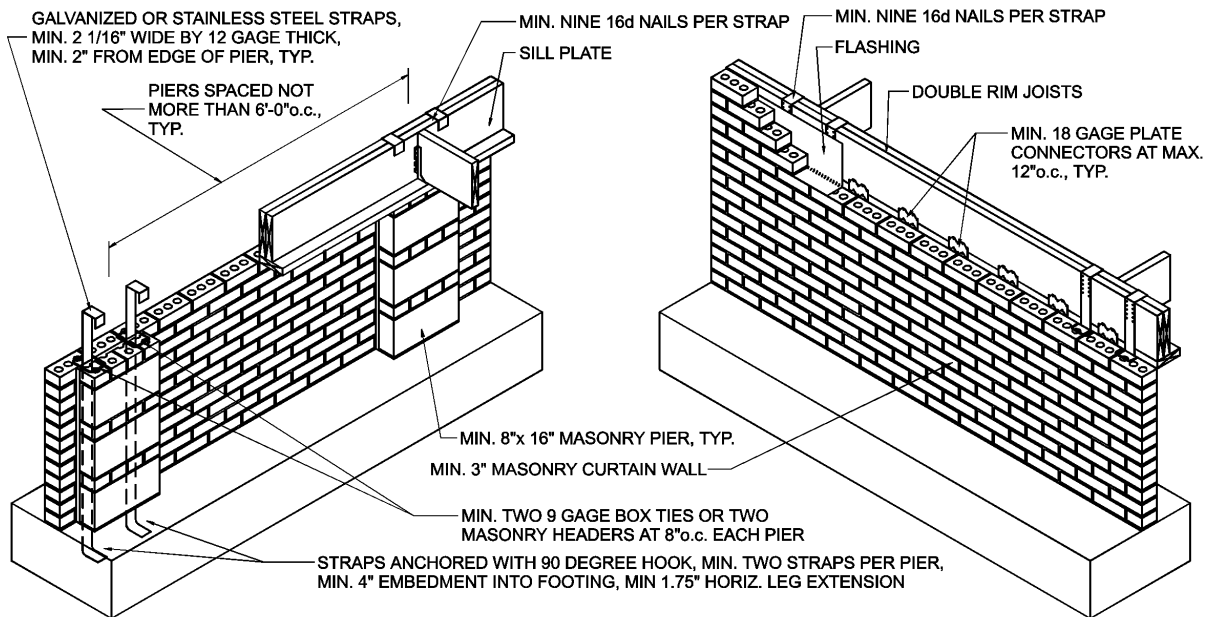


FIGURE 303D3, PART B



**303.3 MONOLITHIC SLAB-ON-GRADE FOUNDATIONS**

**303.3.1** Concrete slabs and footings shall be poured as a monolithic unit. The minimum size and reinforcing requirements for exterior footings for uplift resistance shall be as shown in Table 303D. The outer bar of foundation reinforcing shall be continuous around corners using corner bars or by bending the bar. Minimum bar lap shall be 25 inches.

**TABLE 303D  
MINIMUM MONOLITHIC FOOTING SIZE – 1 & 2 STORY**

	<b>T<sup>1</sup></b>	<b>W</b>	<b>Reinforcing</b>
One Story	20"	12"	2 - #5
Two Stories	20"	16"	2 - #5

1. Thickness of footing includes thickness of slab.

**303.3.2 Wall to Foundation Anchorage:** Wall bottom plates shall be anchored to a slab-on-grade foundation system with anchor bolts having a minimum bolt diameter of 5/8 inch and 3"x3"x1/8" washers. A minimum of one anchor bolt shall be provided within 6 to 12 inches of each end of each plate. Anchor bolts shall have a minimum embedment of 7 inches in concrete slabs-on-grade. Anchor bolts shall be located within 12 inches of corners and at spacings as specified in Table 303.3.2 for anchor bolts resisting lateral, shear, and uplift loads. Approved alternative plate anchors and wall anchoring systems shall be installed in accordance with the manufacturer's published recommendations and shall meet the following design requirements.

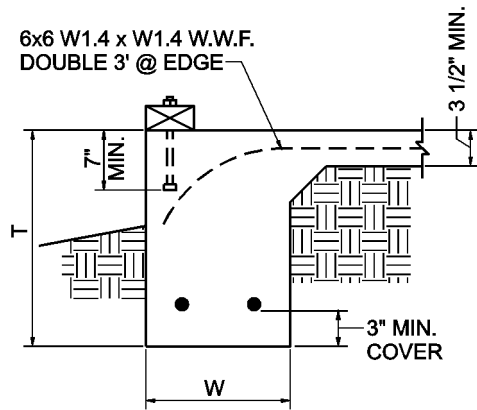
- a. Shear in the plane of the wall per Tables 305P1 through 305P3.
- b. Uplift loads per Tables 305F1 and 305F2.
- c. Lateral loads perpendicular to the plane of the wall equal to 213 plf.

When uplift connectors are provided at every full length stud and are continuous from the exterior wall into the foundation wall, anchor bolt spacings may be increased to 3 feet on center for one story buildings. Standard washers may be used (See Table 303.3.2).

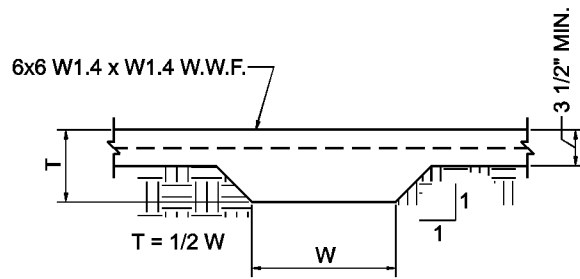
**TABLE 303.3.2  
WALL TO FOUNDATION ANCHORAGE**

		<b>Fastest Mile Windspeed (mph)</b>		
		<b>90</b>	<b>100</b>	<b>110</b>
<b>Anchor Bolt Resisting</b>	<b>Foundation Supporting:</b>	<b>Maximum Anchor Bolt Spacing (ft)</b>		
Lateral, Shear & Uplift Loads	1 Story	2	1 1/2	1 1/2
	2 Stories	2	1 1/2	1 1/2
Lateral & Shear Loads Only	1 Story	3	3	3
	2 Stories	2	1 1/2	1 1/2

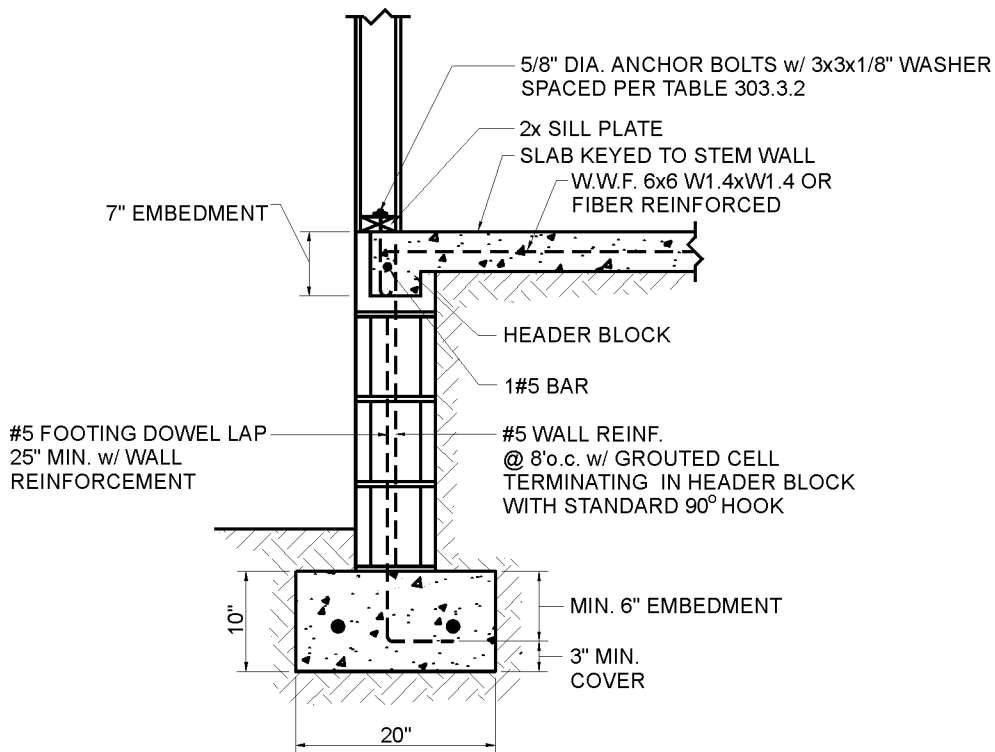
**303.3.3 Interior Footings:** Under slabs, interior footings shall be the width, W, of the exterior footings and the thickness, T, shall be a minimum of one half the width, W (See Figure 303F).



**FIGURE 303E**  
**MONOLITHIC EXTERIOR FOOTING**



**FIGURE 303F**  
**MONOLITHIC INTERIOR FOOTING**



**FIGURE 303G**  
**STEMWALL FOUNDATION WITH SLAB-ON-GRADE**

**303.4 WOOD PILES**

**303.4.1 Piles:** Piles supporting structures shall be designed by a registered engineer or architect.

**303.4.2 Girders:** Girders, including connections to piles, shall be designed by a registered engineer or architect.

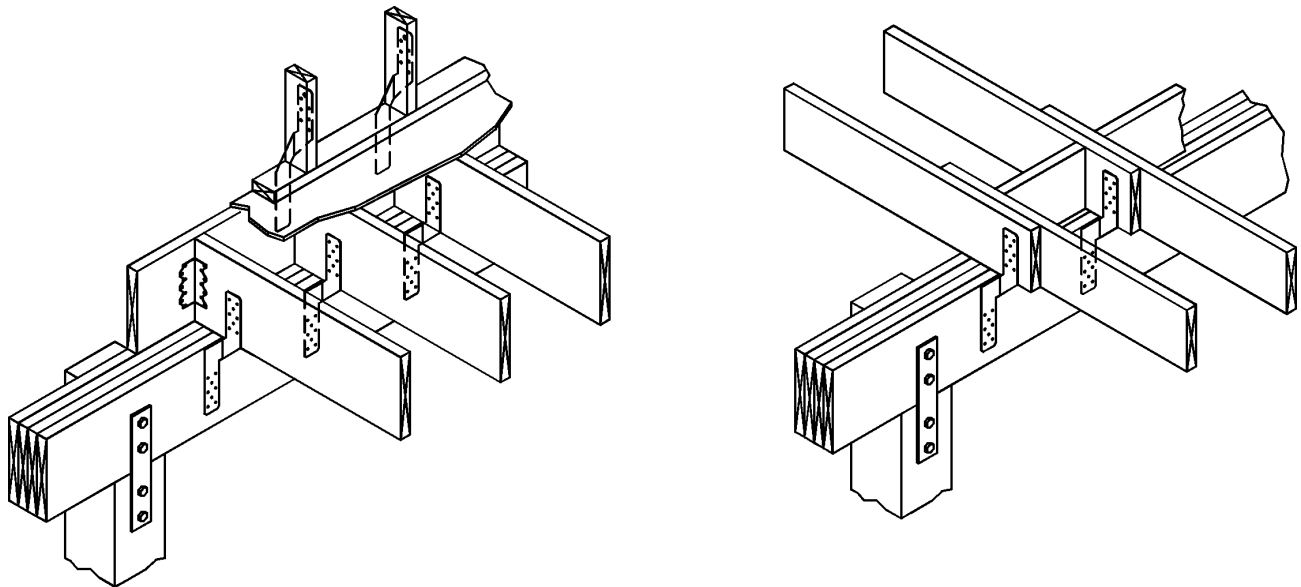
**303.4.3 Preservative Treatment:** All wood piles shall be preservatively treated in accordance with the requirements of AWPA C3 for Piles or AWPA C24 for Sawn Timber Piles.

**303.4.4 Structural Loads:** The piles and girders shall be designed to resist uplift, shear, and lateral loads. The uplift and shear design loads on the girders and piles shall be not less than the figures shown in Table 303G.

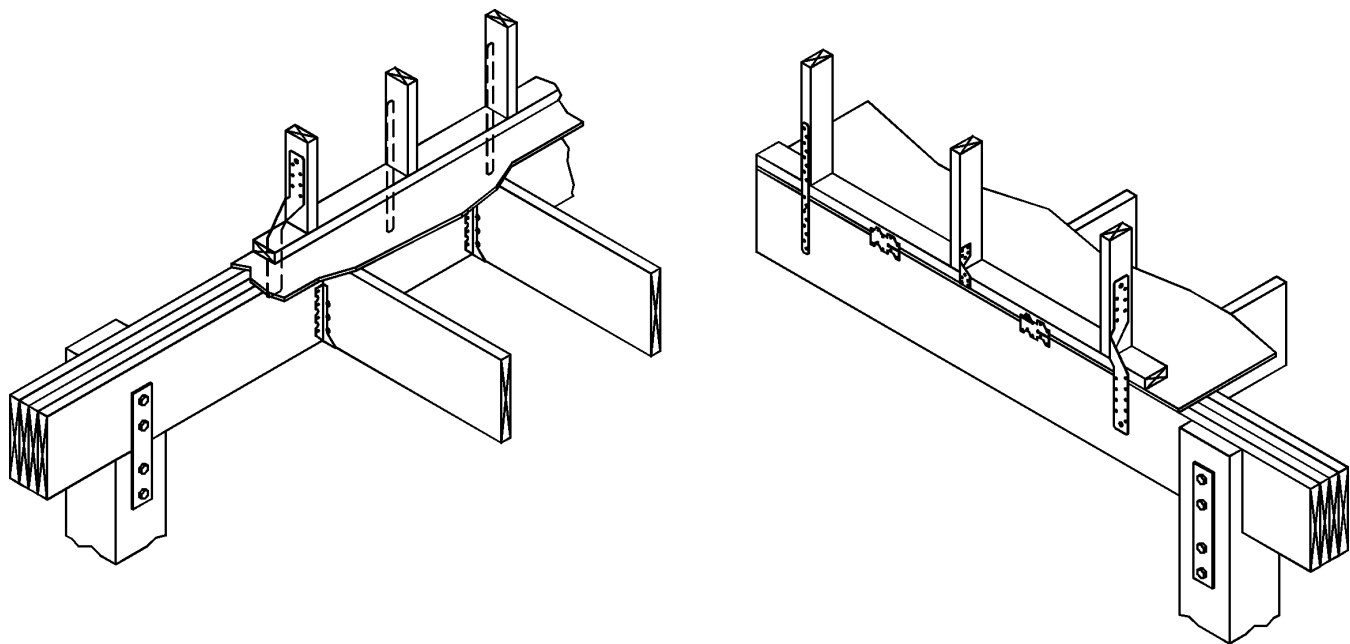
**TABLE 303G  
MINIMUM UPLIFT AND SHEAR LOADS ON GIRDERS**

	90 mph	100 mph	110 mph
<b>Uplift on Girders (plf)</b>			
1 Story	375	575	775
2 Story	200	450	700
<b>Shear on Girders (plf)</b>			
1 Story	250	300	350
2 Story	550	675	825

**303.4.5 Connections:** The exterior walls shall be anchored to the girders and shall be able to resist the loads in Table 303G. Holddown connectors for shearwalls are required. The size and bolt requirements of the holddown connectors shall be in accordance with 305.7 and shall be installed in accordance with the recommendations of the manufacturer.



**FIGURE 303I  
FLOOR JOIST OVER GIRDER  
WALL TO GIRDER CONNECTION**



**FIGURE 303J**  
**FLOOR JOIST TO GIRDER CONNECTIONS**

### 304 FLOOR SYSTEMS

#### 304.1 CONCRETE FLOORS

**304.1.1** Concrete floors may be cast in place or of precast hollow core units.

**304.1.2** A concrete slab-on-grade used in conjunction with the exterior stemwall foundations described in 303.2 shall have 6x6 W1.4 X W1.4 welded wire fabric or synthetic fiber reinforcement in the slab and the slab shall be keyed into or tied to the foundation.

**304.1.3** The top of a monolithic slab-on-grade shall be at least 8 inches above finished grade. The slab shall be not less than 3 1/2 inches thick. The slab shall have 6x6 W1.4 X W1.4 welded wire fabric at mid-height or synthetic fiber reinforcement. A double layer of 6x6 W1.4 X W1.4 welded wire fabric 3 feet wide shall be provided around the perimeter of the slab (See Figure 303E).

#### 304.2 WOOD FLOORS

**304.2.1 Floor Joists:** Floor joists shall be sized in accordance with the American Forest and Paper Association's (AF & PA) Span Tables for Joists and Rafters.

**304.2.2 Wood I-Joists:** Single or continuous span I-joists shall comply with the manufacturer's code evaluation report.

**304.2.3 Floor Trusses:** Parallel chord floor trusses shall be in accordance with TPI Design Specifications for Metal Plate Connected Parallel Chord Wood Trusses.

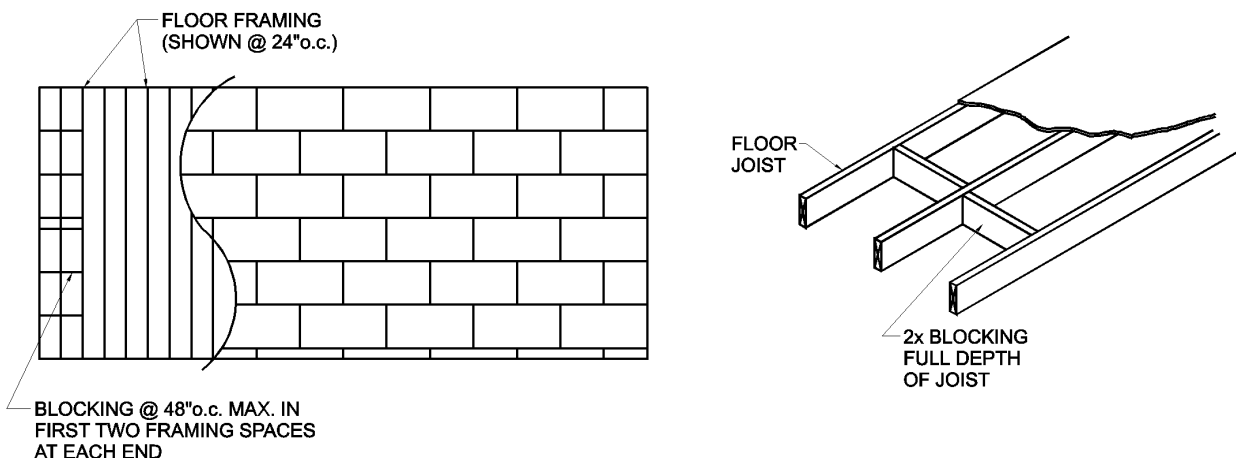
**304.2.4 Floor Sheathing Thickness:** Floor sheathing shall be a minimum of 7/16-inch wood structural panels installed with long dimension perpendicular to framing and with end joints staggered (See Figure 304A).

**304.2.5 Floor Sheathing Spans:** Floor framing shall be spaced such that the sheathing spans do not exceed those specified in Table 2307.6B of the Standard Building Code. In no case shall spacing exceed span ratings shown on panels.

**304.2.6 Connections:** The floor joists/trusses shall be fastened to the sill plate or top plate in accordance with Section 2306 of the Standard Building Code (See Appendix E). In addition, uplift connectors shall be provided to resist uplift loads shown in Tables 305F1-F2 (See 305.3.2).

**304.2.7 Bracing:** Bracing provides full depth blocking, perpendicular to the floor framing members in the first two framing spaces at each end of floor system, spaced 4 feet on center maximum (See Figure 304A).

**304.2.8 Fastening:** Fastening shall be in accordance with Section 2306 of the Standard Building Code (provided in Appendix E of this Standard) and Tables 304C1 and 304C2, in order to provide the required shear capacities.



**FIGURE 304A  
FLOOR BRACING AT ENDWALLS**

**304.3 FLOOR DIAPHRAGMS**

Floor sheathing and fasteners shall be capable of resisting the total shear loads specified in Table 304B1 and 304B2 for the applicable distance between shear walls. Shear capacities for wood floor diaphragms shall be based on the spacing of the floor framing members, sheathing material, sheathing thickness, nail size and nail spacing as specified in Table 304C1 and Table 304C2.

**TABLE 304B1  
FLOOR DIAPHRAGM REQUIREMENTS AT SIDEWALLS  
(Wind Parallel to Sidewalls)**

Floor	Required Floor Diaphragm Shear Capacity (plf) <sup>1,2</sup>		
	90 mph	100 mph	110 mph
<b>2nd Floor of Two Story</b>	95	115	140
<b>1st Floor over Crawl Space</b>	60	75	90

1. The values in the table above assume an 8 ft wall height. When using a wall height of 10 ft, the required shear capacity shall be increased by 25 percent.
2. For floors on pile foundations, use Second Floor requirements.
3. When building length (L) is not equal to building width (W), multiply table values by W divided by L (W/L).

**TABLE 304B2  
FLOOR DIAPHRAGM REQUIREMENTS AT ENDWALLS  
(Wind Parallel to Endwalls)**

Maximum Distance Between Shearwalls	Required Floor Diaphragm Shear Capacity (plf) <sup>1,2</sup>					
	90 mph		100mph		110 mph	
	1st Floor	2nd Floor	1st Floor	2nd Floor	1st Floor	2nd Floor
W	80	130	100	160	120	190
2W	150	230	180	285	220	345
3W	215	335	265	410	320	500
4W	280	435	345	540	415	650

1. The values in the table above assume an 8 ft wall height. When using a wall height of 10 ft, the required shear capacity shall be increased by 25 percent.
2. For floors on pile foundations, use Second Floor requirements.

**TABLE 304C1  
SHEAR CAPACITIES FOR HORIZONTAL DIAPHRAGM ASSEMBLIES**

Sheathing Material	Sheathing Thickness	Nail Size	Framing Species G ≤ 0.49					Framing Species 0.49 > G ≤ 0.42					Framing Species G < 0.42					
			Panel Edge Nail Spacing (in.) <sup>3</sup>															
			Blocked Diaphragms					Blocked Diaphragms					Blocked Diaphragms					
			6 <sup>2</sup>	6	4	3	2 <sup>1</sup>	6 <sup>2</sup>	6	4	3	2 <sup>1</sup>	6 <sup>2</sup>	6	4	3	2 <sup>1</sup>	
Allowable Shear Capacity (plf)																		
Structural I	3/8	8d	250	380	505	740	840	210	310	415	610	685	160	245	330	485	545	
	15/32	10d	300	450	595	895	1020	245	365	490	735	840	195	295	385	580	665	
Sheathing Grade	3/8	6d	175	260	350	525	590	145	210	285	435	485	110	170	230	345	385	
		8d	225	335	450	670	765	210	310	415	610	685	160	245	330	485	545	
	15/32	7/16	8d	240	355	475	705	805	210	310	415	610	685	160	245	330	485	545
		8d	250	380	505	740	840	210	310	415	610	685	160	245	330	485	545	
			10d	265	405	540	805	915	245	365	490	735	840	195	295	385	580	665
19/32	10d	300	450	595	895	1020	245	365	490	735	840	195	295	385	580	665		

G - Specific gravity of framing species

1. Framing shall be 3 inches nominal or wider and nails shall be staggered.
2. When panel edges are staggered over common framing members, and the load is parallel to the framing members, tabulated values shall be permitted to be increased 33%.
3. Nails of the same size required for panel edges shall be placed along all intermediate framing at 12 inches on center.

**TABLE 304C2  
SHEAR CAPACITIES FOR HORIZONTAL DIAPHRAGM ASSEMBLIES**

Sheathing Material	Thickness of Material	Nail Size	Diaphragm Construction	Nail Spacing (in.)		Shear Capacity (plf)
				Panel Edges	Intermediate Supports	
Gypsum Wallboard	1/2	5d Cooler Nails or 1-1/4 Drywall Screws	Unblocked <sup>1</sup>	7	10	70 <sup>2</sup>
Lumber Sheathing	5/8 or 3/4	8d Common Nails	Straight Sheathing	2 per Support	2 per Support	50
			Diagonal Sheathing	2 per Support	2 per Support	300
			Special 2-Layer Diagonal Sheathing	2 per Support/Layer	2 per Support/Layer	600

1. Solid blocking is required at the diaphragm perimeter.
2. Tabulated shear capacity can be increased to 90 plf when ceiling framing members are spaced not more than 16 inches on center.

### 305 WOOD-FRAMED WALL SYSTEMS

#### 305.1 GENERAL

**305.1.1** Under this Standard, exterior walls shall be designed to resist lateral forces (perpendicular to the plane of the wall), uplift forces (vertically in the plane of the wall), and shear forces (horizontally in the plane of the wall). The designs shall be based on wind speed, the size, spacing, and bending strength of studs, the fastening and connecting of all framing members, and the thickness, strength, stud length and attachment methods of exterior and interior sheathing.

**305.1.2** Where a specific species and grade of lumber is given in tables in this Standard, a species and grade with equivalent or greater design values is permitted. The design values contained in Design Values for Wood Construction, a supplement to the National Design Specification for Wood Construction, shall be used to determine equivalency of substituted material. Adjusted  $F_b$  values for some common species are shown in Table 305A.

**TABLE 305A**  
**F<sub>b</sub> VALUES FOR STUDS RESISTING WIND**

ALLOWABLE F <sub>b</sub> FOR COMMON SPECIE COMBINATIONS AND GRADES							
Lumber Species Combinations	Grade	Exterior Sheathing					
		Minimum Sheathing Materials <sup>1</sup>			Wood Structural Panels <sup>3</sup>		
		2x4	2x6	2x8	2x4	2x6	2x8
		<sup>2</sup> Allowable F <sub>b</sub>			<sup>4</sup> Allowable F <sub>b</sub>		
Douglas Fir-Larch	SS	4000	3450	3200	5200	4200	3600
	#1	2750	2400	2200	3600	2900	2500
	#2	2400	2100	1950	3100	2550	2200
	#3	1400	1200	1100	1800	1450	1250
	Stud	1350	1250	—	1750	1500	—
	Const. Std.	1850	—	—	2400	—	—
	Std.	1000	—	—	1300	—	—
Hem-Fir	SS	3850	3350	3100	5000	4100	3500
	#1	2600	2250	2100	3400	2750	2350
	#2	2350	2050	1900	3050	2500	2150
	#3	1400	1200	1100	1800	1450	1250
	Stud	1350	1250	—	1750	1500	—
	Const. Std.	1800	—	—	2350	—	—
	Std.	1000	—	—	1300	—	—
Southern Pine	SS	5250	4700	4250	6800	5700	4800
	#1	3400	3050	2750	4400	3700	3100
	#2	2750	2300	2200	3600	2800	2500
	#3	1550	1400	1300	2000	1700	1450
	Stud	1600	1450	—	2100	1750	—
	Const. Std.	2000	—	—	2600	—	—
	Std.	1150	—	—	1500	—	—
Spruce-Pine-Fir	SS	3450	3000	2750	4500	3650	3100
	#1&#2	2400	2100	1950	3100	2550	2200
	#3	1400	1200	1100	1800	1450	1250
	Stud	1350	1250	—	1750	1500	—
	Const. Std.	1800	—	—	2350	—	—
	Std.	1000	—	—	1300	—	—

1. These values assume minimum sheathing material capable of distributing loads to the studs.
2. These values and values for other species can be found in the American Forest and Paper Association's (AF&PA) 1991 National Design Specification for Wood Construction (ANSI/NFPA NDS-1991). These values have been increased using the size factor, load duration, and repetitive member adjustments. The repetitive member adjustment assumes minimum sheathing materials are used.
3. These values take into consideration the load sharing and composite action of the structural sheathing with studs spaced no more than 16 inches on center. They require a minimum of 1/2" gypsum board wall covering on the inside fastened in accordance with Appendix E and 3/8" wood structural sheathing attached with 8d nails at a maximum of 6 inches o.c. at the perimeter and 12 inches o.c. at intermediate supports.
4. These values are based on the values found in the American Forest and Paper Association's (AF&PA) 1991 National Design Specification for Wood Construction (ANSI/NFPA NDS-1991). These values have been increased using the size factor, load duration, and system factor adjustments. The system factor adjustments assume 3/8" wood structural panels are used. System factor adjustments are as follows:

Stud Size	System Factor
2x4	1.5
2x6	1.4
2x8	1.3
2x10	1.2
2x12	1.15



**305.2 EXTERIOR WALL FRAMING**

**305.2.1 Stud:** The minimum bending strength ( $F_b$ ) of studs for a given size, length, and spacing shall be those shown in Tables 305B1 and 2. The requirements for studs have been keyed to the bending stress,  $F_b$ , for normal duration of load. Studs shall be placed with the wide face perpendicular to the wall.

**TABLE 305B1  
MINIMUM  $F_b$  VALUES REQUIRED FOR EXTERIOR LOADBEARING STUDS**

Stud Length <sup>1</sup>	Stud Spacing	90 mph			100 mph			110 mph		
		Nominal Stud Sizes								
		2x4	2x6	2x8	2x4	2x6	2x8	2x4	2x6	2x8
Minimum $F_b$ Required										
8'	12 in.	900	375	200	1100	450	250	1350	550	325
	16 in.	1200	500	275	1500	600	350	1800	725	425
	24 in.	1800	725	425	2250	900	525	2700	1100	625
10'	12 in.	1400	575	325	1750	700	400	2100	850	500
	16 in.	1900	775	450	2350	950	550	2850	1150	650
	24 in.	2850	1150	675	3500	1400	825	4250	1700	1000

1. Engineering design and calculations are required for loadbearing studs longer than 10 feet.

**TABLE 305B2  
MINIMUM  $F_b$  VALUES REQUIRED FOR EXTERIOR NON-LOADBEARING STUDS**

Stud Length	Stud Spacing	90 mph			100 mph			110 mph		
		Nominal Stud Sizes								
		2x4	2x6	2x8	2x4	2x6	2x8	2x4	2x6	2x8
Minimum $F_b$ Required										
8'	12 in.	900	375	200	1100	450	250	1350	550	325
	16 in.	1200	500	275	1500	600	350	1800	725	425
	24 in.	1800	725	425	2250	900	525	2700	1100	625
10'	12 in.	1400	575	325	1750	700	400	2100	850	500
	16 in.	1900	775	450	2350	950	550	2850	1150	650
	24 in.	2850	1150	675	3500	1400	825	4250	1700	1000
12'	12 in.	2050	825	475	2550	1000	600	3050	1250	725
	16 in.	2750	1100	625	3350	1350	775	4100	1650	950
	24 in.	4100	1650	950	5050	2050	1200	—	2500	1450
14'	12 in.	2800	1150	650	3450	1400	800	4150	1700	975
	16 in.	3700	1500	875	4600	1850	1050	5550	2250	1300
	24 in.	5550	2250	1300	—	2800	1600	—	3350	1950
16'	12 in.	3650	1450	850	4500	1800	1050	5450	2200	1250
	16 in.	4850	1950	1150	6000	2450	1400	—	2950	1700
	24 in.	—	2950	1700	—	3650	2100	—	4400	2550
18'	12 in.	4600	1850	1050	5700	2300	1350	—	2800	1600
	16 in.	—	2500	1450	—	3050	1750	—	3700	2150
	24 in.	—	3750	2150	—	4600	2650	—	5550	3200
20'	12 in.	5700	2300	1350	—	2850	1650	—	3450	2000
	16 in.	—	3050	1750	—	3800	2200	—	4600	2650
	24 in.	—	4600	2650	—	5700	3250	—	—	3950

**305.2.2 Gable Endwalls:** Gable endwalls shall be built using full-height studs continuous from the uppermost floor to the underside of the roof (See Figure 305J). Where full-height gable endwalls are not possible, an attic floor or ceiling diaphragm shall be provided to resist the lateral loads at the horizontal joint between the top plate of a platform-framed endwall and the gable construction above; per 306.

**305.2.3 Headers.**

**305.2.3.1 Header Beams:** Header beams shall be provided and sized in accordance with Section 2308.3 of the Standard Building Code. The minimum number of header studs supporting each end of a header beam and the minimum number of full-length wall studs at each end of a header beam shall be in accordance with Table 305C.

**305.2.3.2 Header Studs:** Exterior header studs and full height studs shall be in accordance with 305.2.1.

**305.2.3.3 Connections at Headers:** Uplift connectors shall be provided at the top and bottom of cripple studs, header studs, and at least one wall stud at each side of opening (See 305.3) (See Figures 305D and 305E).

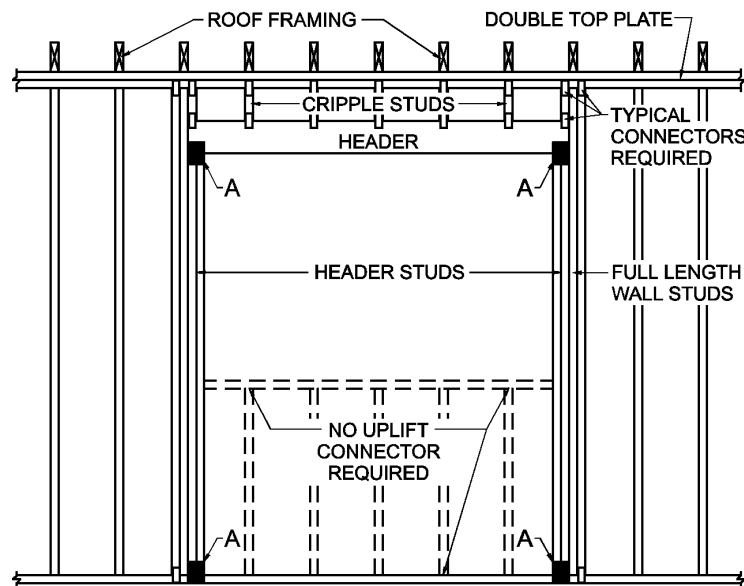
**TABLE 305C  
MINIMUM WALL AND HEADER STUD REQUIREMENTS**

		Maximum Header Span (ft.)					
		3'	6'	9'	12'	15'	18'
		Number of Header Studs Supporting End of Header					
		1 <sup>1</sup>	1	2	2	2	2
Unsupported Wall Height	Stud Spacing	Number of Full-Length Studs at Each End of Header					
10' or less	12 in.	2	2	3	3	3	3
	16 in.	2	2	3	3	3	3
	24 in.	1	2	2	2	2	2
greater than 10'	12 in.	2	2	3	4	5	5
	16 in.	2	2	3	3	4	4
	24 in.	1	2	2	2	3	3

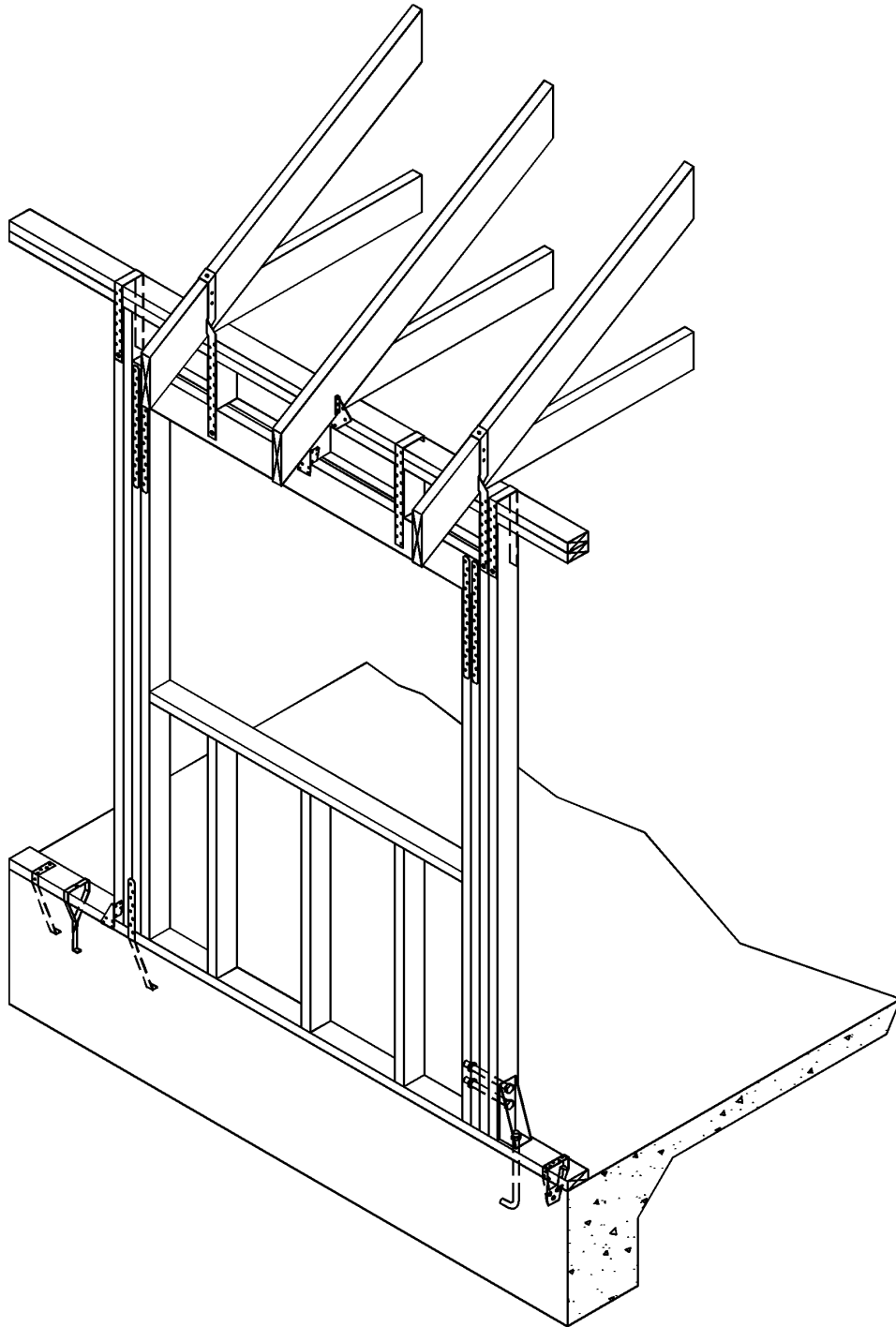
1. The header stud shall not be required if the header is supported by a suitable framing anchor.

Uplift connection requirement at points A (top and bottom of header studs): Uplift load per framing member above the header from Table 305F1 or 307A, as appropriate, multiplied by the number of framing members displaced divided by two.

NOTE: Uplift connection is required at each end of header and at bottom of header studs in addition to connectors at wall studs and at top and bottom of cripples.



**FIGURE 305D  
TYPICAL FRAMING AND UPLIFT CONNECTIONS FOR OPENINGS**



**FIGURE 305E**  
**ILLUSTRATION OF CONNECTOR TYPES**

**305.3 CONNECTIONS FOR EXTERIOR WALL FRAMING**

**305.3.1** Framing members in exterior wall systems shall be fastened together in accordance with Table 2306.1 of the Standard Building Code (See Appendix E). In addition, uplift connectors shall be provided to resist the uplift loads listed in Tables 305F1-2. The uplift load requirements may be interpolated for intermediate building widths.

**305.3.2** Uplift load resistance shall be continuous from roof to foundation. StudS shall be connected to plates and plates to floor framing with connectors designed, rated, and approved for each individual location and condition. When roof framing is connected directly to studs, studs connected directly to floor framing, or upper studs connected directly to lower studs with single connectors designed for the purpose and rated for the loads in the tables, separate plate-to-stud or plate-to-floor-framing uplift connectors may be omitted (See Figures 305G-H).

**305.3.3** Uplift connections for plates to foundations are specified in 303.2.3, 303.2.4, 303.3.2, and 303.4.5.

**305.3.4** Wood structural panel sheathing may be used to resist uplift (See Section 305.6 for uplift values).

**305.3.5** Where “Holddown” connectors occur (See 305.7), connectors required for uplift resistance may be omitted.

**TABLE 305F1  
UPLIFT LOADS AT SIDEWALLS  
(pounds per stud)**

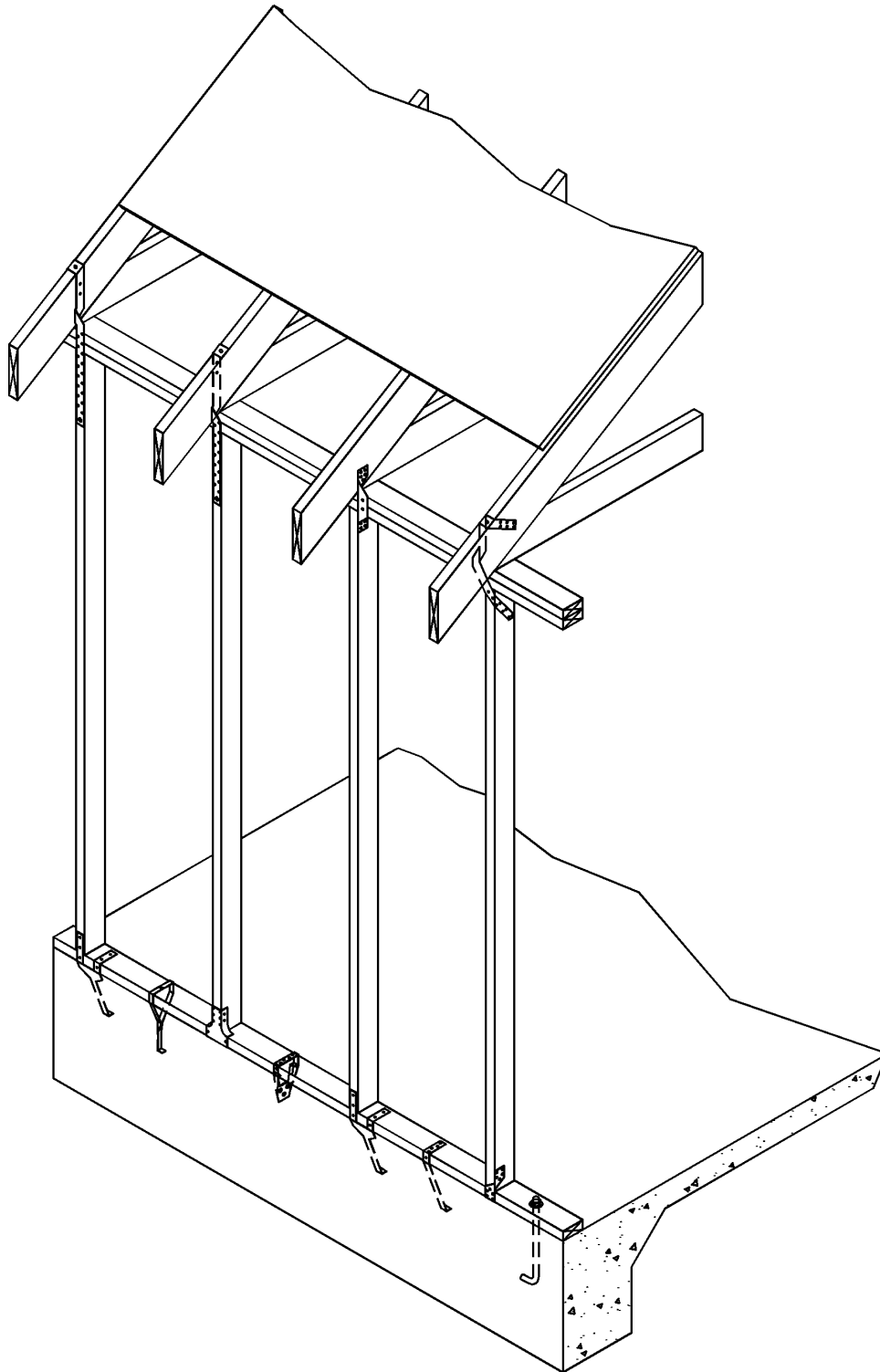
Roof & Ceiling Dead Load <sup>1</sup>	90 mph					100 mph					110 mph				
	Building Width														
	24'	36'	44'	52'	60'	24'	36'	44'	52'	60'	24'	36'	44'	52'	60'
<b>Uplift Loads for 12" stud spacing</b>															
5 psf	310	445	535	630	720	400	570	690	810	930	500	715	860	1005	1155
7 psf	285	405	485	570	655	370	530	640	750	865	470	675	810	950	1090
10 psf	240	345	415	490	560	330	470	570	670	770	430	615	740	870	995
15 psf	170	245	295	350	400	260	370	450	530	610	360	515	620	725	835
20 psf	100	145	175	210	240	190	270	330	390	450	290	415	500	585	675
25 psf	30	45	55	70	80	120	170	210	250	290	220	315	380	445	515
<b>Uplift Loads for 16" stud spacing</b>															
5 psf	415	595	715	835	960	535	765	920	1075	1235	665	950	1145	1340	1540
7 psf	375	540	650	760	875	495	710	855	1000	1150	625	900	1080	1265	1455
10 psf	320	460	555	650	750	440	630	760	890	1025	570	820	985	1155	1330
15 psf	230	325	395	465	535	345	495	600	705	810	480	685	825	970	1115
20 psf	135	195	235	275	320	255	365	440	515	595	385	550	665	780	900
25 psf	40	60	75	90	110	160	230	280	330	385	290	420	505	595	690
<b>Uplift Loads for 24" stud spacing</b>															
5 psf	620	890	1070	1255	1440	800	1145	1380	1615	1855	995	1425	1720	2015	2310
7 psf	565	810	975	1145	1315	745	1065	1280	1505	1725	940	1345	1620	1900	2185
10 psf	480	690	830	975	1120	660	945	1140	1335	1535	855	1225	1480	1735	1990
15 psf	340	490	590	695	800	520	745	900	1055	1215	715	1025	1240	1455	1670
20 psf	200	290	350	415	480	380	545	660	775	890	575	895	1000	1175	1350
25 psf	60	90	110	135	160	240	345	420	495	575	435	625	760	895	1030

- Individual connector ratings shall not be less than 100 lbs for uplift.
- Roof and ceiling dead loads shall be actual loads provided, not counting the roof covering. In the absence of more accurate data, the following roof and ceiling dead loads shall be permitted to be used: 7psf for truss assembly (roof sheathing, trusses, gypsum ceiling); 7 psf for rafter assembly (roof sheathing, rafters, gypsum ceiling); 10 psf for rafter/ceiling assembly (roof sheathing, rafters and ceiling joists connected per Table 2306.1 of the Standard Building Code).  
EXCEPTION: Where roof tile is installed in accordance with the SBCCI Standard for Determining the Wind Resistance of Concrete and Clay Roof Tile, the actual weight of the tile shall be permitted to be included in the total roof and ceiling dead load.

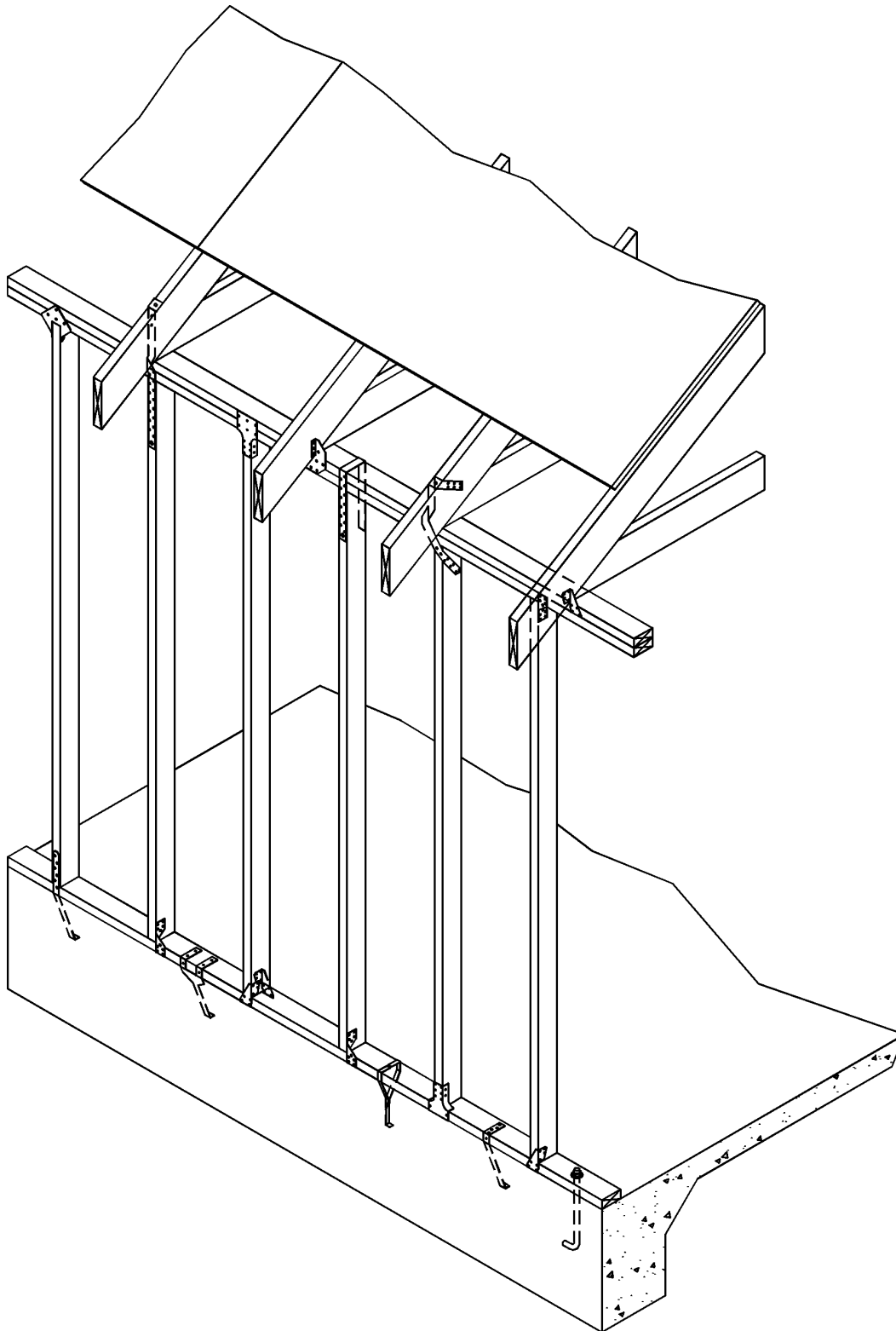
3. The following adjustments shall be permitted (uplift shall not be less than 100 lbs per connector after adjustment).
- The required uplift capacity shall be permitted to be reduced by 30% (multiply by 0.70) for connections at least W/5 from corners but not less than 6 feet.
  - The values in the tables above assume a maximum eave height of 30 ft. When the eave height is 12 ft or less, the values shall be permitted to be reduced by 20% (multiply by 0.80).
  - Footnote 3b shall be permitted to be applied simultaneously with footnote 3a.

**TABLE 305F2  
UPLIFT LOADS AT GABLE ENDWALLS**

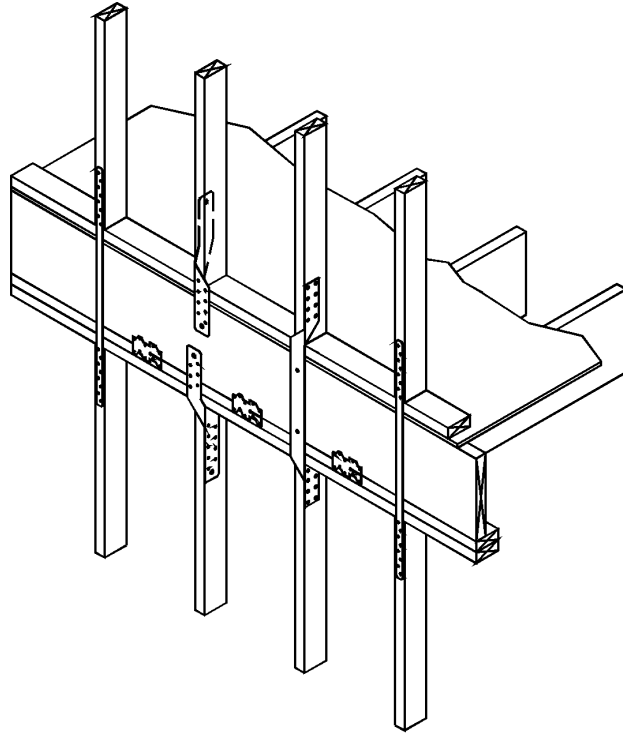
Stud Spacing	90 mph	100 mph	110 mph
	Uplift Loads (lbs/stud)		
12" o.c.	60	75	90
16" o.c.	80	100	120
24" o.c.	120	150	180



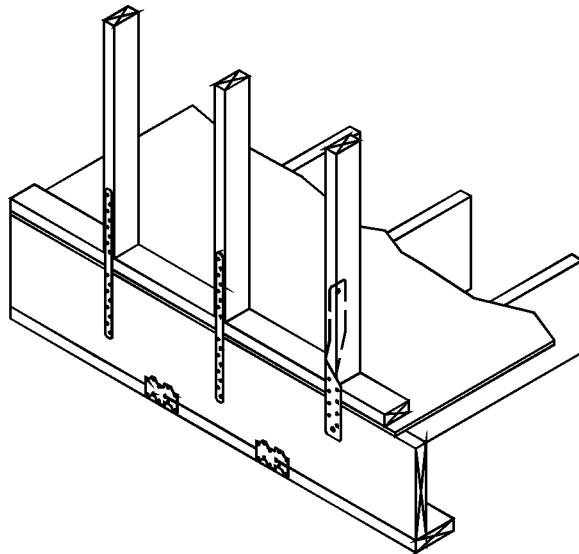
**FIGURE 305G1**  
**TYPICAL WALL CONNECTIONS:**  
**STUD SPACING SAME AS TRUSS/RAFTER SPACING**



**FIGURE 305G2**  
**TYPICAL WALL CONNECTIONS:**  
**STUD SPACING DIFFERENT FROM TRUSS/RAFTER SPACING**

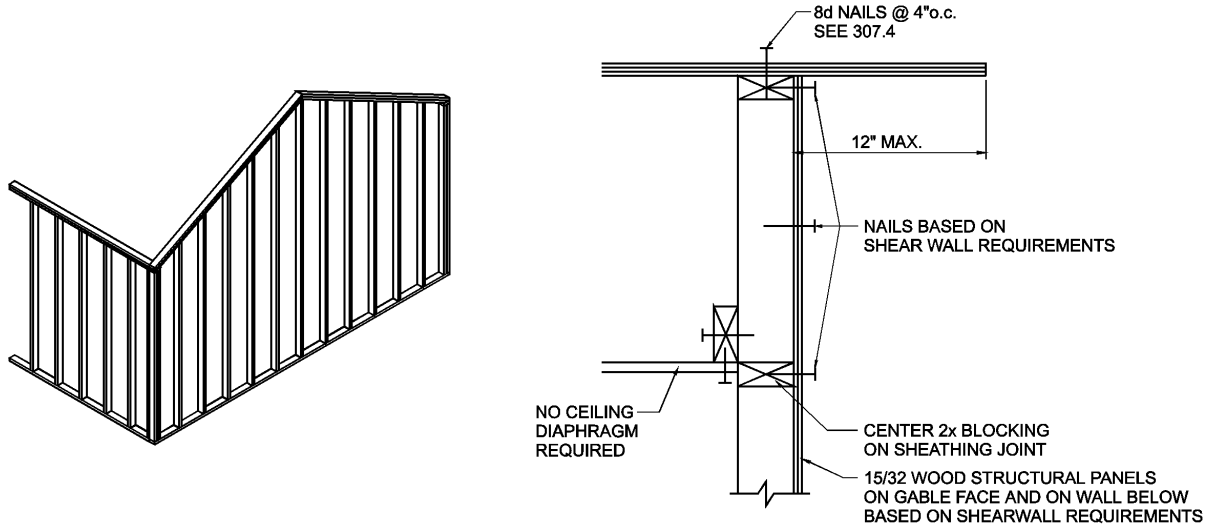


**FIGURE 305H1**  
**CONNECTION DETAILS AT SECOND FLOOR LEVEL**

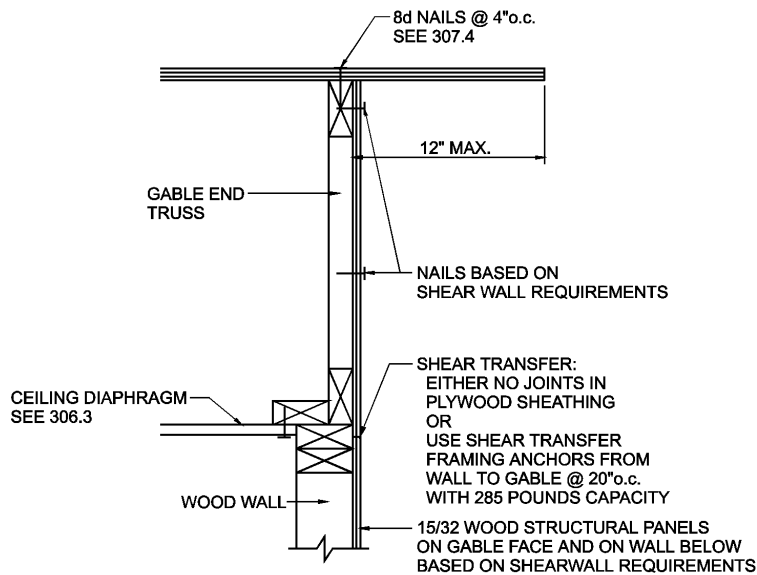


**FIGURE 305H2**  
**CONNECTION DETAILS AT FIRST FLOOR LEVEL**





**FIGURE 305J**  
**GABLE ENDWALL, BALLOON FRAMING**  
**PREFERRED METHOD**



**FIGURE 305K**  
**GABLE ENDWALL, PLATFORM FRAMING**  
**ALTERNATE METHOD**

**305.3.7 Top Plate Splices:** The double top plates of a wall supporting a roof only shall resist the chord forces in the roof diaphragm and act as drag struts between shear wall segments. Joints shall be lap-spliced. Within the center third of a wall length, the minimum lap shall be 4 feet. Lap splices shall be connected with the number of fasteners between each upper and lower plate joint as required by Table 305L1 or 2.

**TABLE 305L1  
NAILS REQUIRED FOR TOP PLATE SPLICE**

Building Length or Distance Between Shearwalls	90 mph					100 mph					110 mph				
	Building Width														
	24'	36'	44'	52'	60'	24'	36'	44'	52'	60'	24'	36'	44'	52'	60'
	<b>Top Plate Splice Number of 16d Common Nails Based on Group III Species</b>														
W	3	5	6	8	10	4	6	8	10	12	4	7	9	12	14
2W	7	10	12	14	16	8	12	15	18	20	10	14	18	21	24
3W	14	21	—	—	—	17	26	—	—	—	21	32	—	—	—
4W	25	—	—	—	—	30	—	—	—	—	37	—	—	—	—

W = Building Width

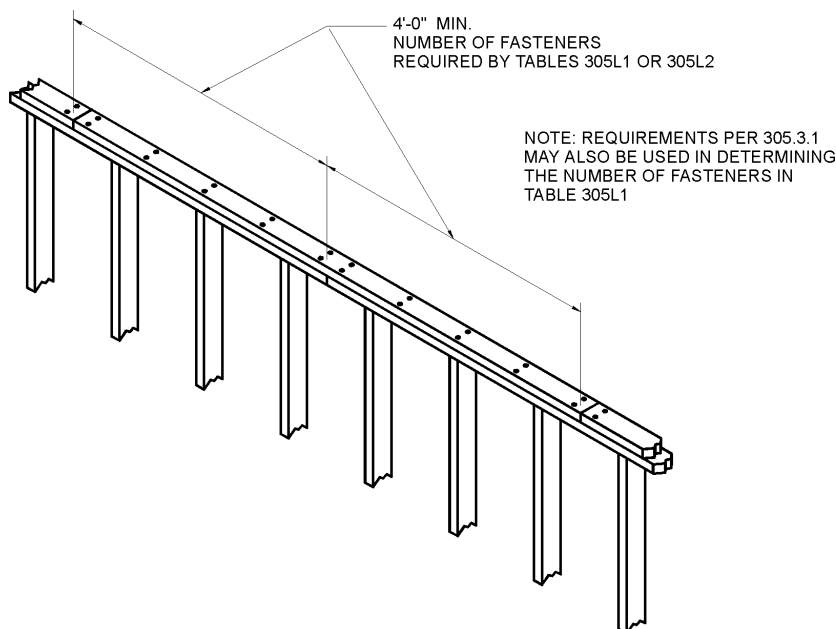
The number of fasteners may be reduced by 25% outside the middle half of the wall length.

**TABLE 305L2  
BOLTS REQUIRED FOR TOP PLATE SPLICE**

Building Length or Distance Between Shearwalls	90 mph					100 mph					110 mph				
	Building Width														
	24'	36'	44'	52'	60'	24'	36'	44'	52'	60'	24'	36'	44'	52'	60'
	<b>Top Plate Splice Number of 1/2-inch Bolts Based on Group III Species</b>														
W	1	2	2	3	3	1	2	3	3	4	2	2	3	4	5
2W	2	3	4	4	5	3	4	5	5	6	3	5	6	6	7
3W	4	7	—	—	—	5	8	—	—	—	6	10	—	—	—
4W	7	—	—	—	—	9	—	—	—	—	11	—	—	—	—

W = Building Width

The number of fasteners may be reduced by 25% outside the middle half of the wall length.



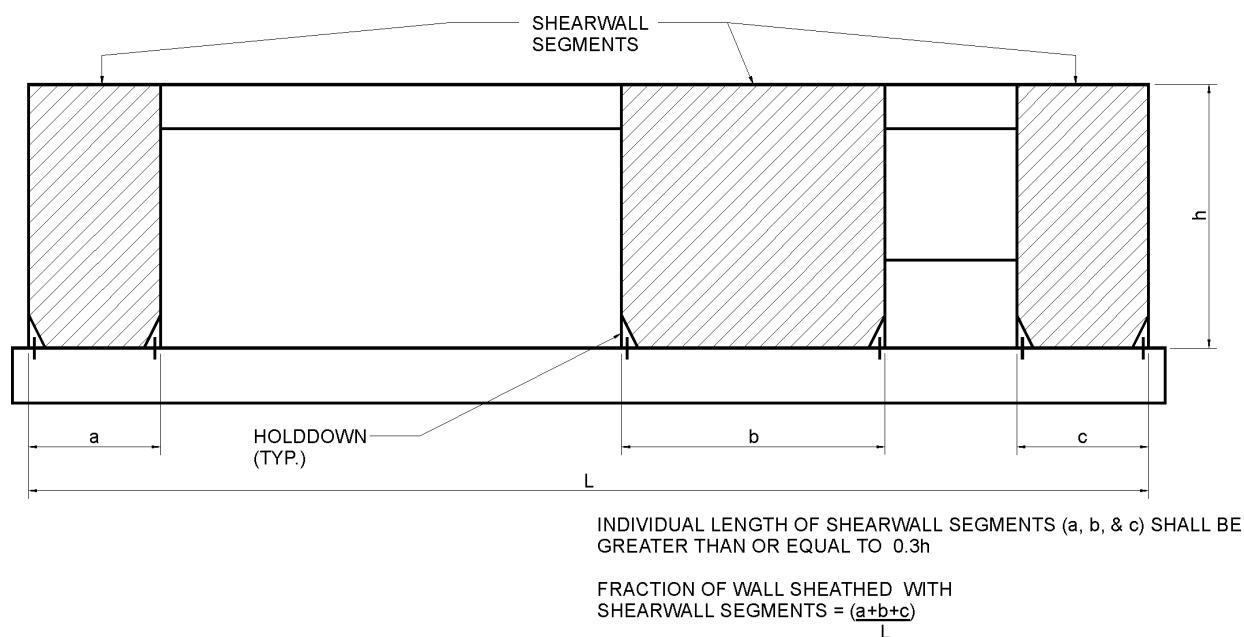
**FIGURE 305L  
TOP PLATE SPLICE FASTENING REQUIREMENTS**

### 305.4 EXTERIOR SHEARWALLS

**305.4.1 General:** Shearwalls are required to resist horizontal forces at roof, ceiling, and floor diaphragm edges. The required length of a shearwall will vary according to the wind speed, building geometry, type of shearwall and material used. The maximum building length between shearwalls shall be 120 feet. Exterior walls are permitted to be constructed as Type I or Type II shearwalls. A holddown is required at each end of each shearwall segment for Type I walls. Holddowns are required only at building corners of Type II walls.

**305.4.2 Type I Walls:** (See Figure 305M1). Portions of walls sheathed with full height sheathing may be used as shearwall segments. To be considered full height sheathing or a shearwall segment, the minimum length of the sheathing shall be 30% of its height. Shearwall segments may be added together to achieve the required effective wall length. Shearwall segments shall have no openings greater than 144 sq in or with any dimension greater than 12 inches. Each corner shall be sheathed for at least 27 inches for 8 foot wall heights and 34 inches for 10 foot wall heights and shall be counted as a shearwall segment. Otherwise, shearwall segments may be arranged in any manner to achieve the required length of shearwall segments. Studs shall be doubled at each end of each shearwall segment. All shearwall segments shall be connected by double top plate drag struts (See 305.3.7).

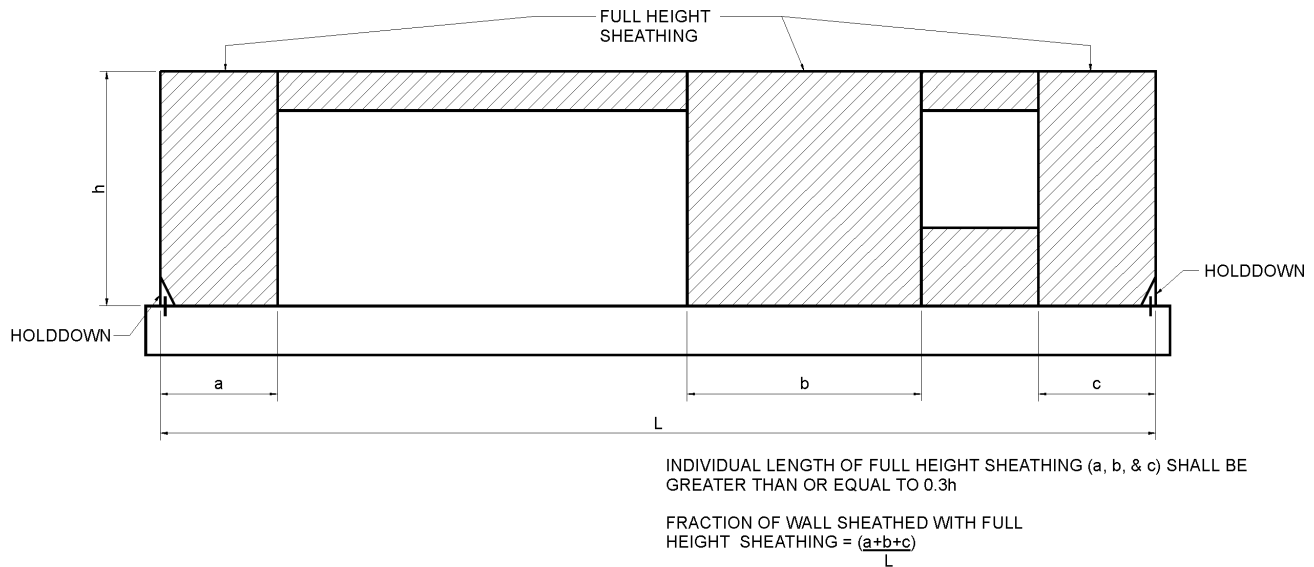
Each exterior wall of the structure shall have full height structural sheathing with the required shear capacity as provided in Tables 305P1 and 305P2. Required shearwall segment capacity for each exterior wall is given as a fraction of the building dimension sheathed with shearwall segments, number of stories, and building L/W ratio. The required shear capacities shall be interpolated for intermediate building length to width ratios.



**FIGURE 305M1**  
**SHEARWALL SEGMENTS OF TYPE I WALLS**

**305.4.3 Type II Walls:** (See Figure 305M2) Type II walls shall meet the requirements of Tables 305P1 and 305P2 multiplied by the appropriate required shear capacity adjustment factor of Table 305P3. To be considered full height sheathing, the minimum length of the sheathing shall be 30% of its height. Full height sheathing lengths shall have no openings greater than 144 sq in or with any dimension greater than 12 inches. The maximum unrestrained opening height of Table 305P3 is the largest vertical dimension of any of the openings in the wall. Areas above and below all openings shall be sheathed and fastened as required for full height sheathing or the maximum unrestrained opening height shall be the height of the wall. Each corner shall be sheathed for at least 27 inches for 8 foot wall heights and 34 inches for 10 foot wall heights and shall be counted as full height sheathing. Studs shall be doubled at each end of a Type II wall. All Type II walls shall have double top plate drag struts (See 305.3.7).

Each exterior wall of the structure shall have full height structural sheathing with the required shear capacity provided in Tables 305P1 and 305P2 multiplied by the required shear capacity adjustment factors of Table 305P3. Required shearwall capacity for each exterior wall is given as a fraction of the building dimension sheathed with full height sheathing, number of stories, and building L/W ratio. The required shear capacities shall be interpolated for intermediate building length to width ratios.



**FIGURE 305M2**  
**FULL HEIGHT SHEATHING OF TYPE II WALLS**

**305.4.4 Sheathing:** For exterior shearwalls, sheathing shall be wood structural panels, particleboard, or other approved structural sheathing material. All sheathing shall be attached to framing along all four edges with joints for adjacent panels occurring over common framing members or along blocking. Sheathing shall be attached to the top member of double top plates. All nails shall be common or hot dipped galvanized box nails. The required shearwall segment length and full height sheathing length is based on the capacity of the sheathing material. Shear capacities for some common structural sheathing materials are shown in Table 305N1 and Table 305N2. The allowable shear capacity of shearwall segments sheathed on both sides with similar materials shall equal the sum of the shear capacities of each side separately.

**EXCEPTION:** The allowable shear capacity of shearwall segments sheathed with a combination of wood structural panels and gypsum wallboard on opposite sides shall equal the sum of the shear capacities of each side separately provided the wall is constructed in accordance with the following physical limitations:

1. For Type I walls, the minimum length of a shearwall segment shall be 50% of its height.
2. For Type II walls, the minimum length of full height sheathing shall be 50% of its height.

**TABLE 305N1  
SHEAR CAPACITIES FOR SHEARWALL MATERIALS**

Sheathing Material	Sheathing Thickness(in.)	Nail Size <sup>2</sup>	Framing Species G 0.49				Framing Species 0.49 > G 0.42				Framing Species G < 0.42			
			Panel Edge Nail Spacing (in.) <sup>5</sup>											
			6	4	3	2 <sup>1</sup>	6	4	3	2 <sup>1</sup>	6	4	3	2 <sup>1</sup>
Recommended Shear Capacity (plf)														
Structural I	5/16	6d	280	420	545	715	230	345	450	590	180	275	355	460
	3/8	8d	320	505	645	855	320	495	630	840	250	390	505	665
	7/16	8d	355	555	705	940	320	495	630	840	250	390	505	665
	15/32	8d	390	600	770	1020	320	495	630	840	250	390	505	665
10d		475	715	930	1220	390	590	765	1000	310	460	600	790	
Sheathing Grade, Plywood Siding <sup>4</sup>	5/16	6d	250	380	490	630	230	345	450	590	180	275	355	460
	3/8	6d	280	420	545	715	230	345	450	590	180	275	355	460
		8d	310	450	575	740	310	450	575	740	250	390	505	665
	7/16	8d	335	490	630	820	320	490	630	820	250	390	505	665
	15/32	8d	365	530	685	895	320	495	630	840	250	390	505	665
		10d	435	645	840	1080	390	590	765	1000	310	460	600	790
19/32	10d	475	715	930	1220	390	590	765	1000	310	460	600	790	
Plywood Siding <sup>4</sup>	5/16	6d <sup>3</sup>	195	295	385	505	160	245	315	415	125	190	250	330
	3/8	8d <sup>3</sup>	225	335	435	575	180	280	355	475	145	215	280	371

G - Specific gravity of framing species

1. Where panels edges abut, framing shall be a minimum of 3 inches nominal in thickness, and nails shall be staggered.
2. Common or galvanized box nails.
3. Galvanized casing or siding nails.
4. Thickness at point of nailing along panel edges governs shear values.
5. Nails of the same size required for panel edges shall be placed along all intermediate framing at 12 inches on center.

**TABLE 305N2  
SHEAR CAPACITIES FOR SHEARWALL MATERIALS**

Sheathing Material	Thickness of Material (in.)	Nail Size	Wall Construction	Nail Spacing (in.)		Recommended Shear Capacity (plf)
				Panel Edges	Intermediate Supports	
Cellulosic Fiberboard Sheathing - Regular	1/2	6d	Blocked	3	6	125
Cellulosic Fiberboard Sheathing - Structural	1/2	8d	Blocked	3	6	175
	25/32	8d	Blocked	3	6	175
Woven or welded wire lath and portland cement plaster	7/8	11 ga. Screws or 16 ga. Staples	Unblocked	6	10	180
Gypsum lath, plain or perforated	3/8" lath and 1/2" plaster	13 ga. Plasterboard Nails	Unblocked	5	10	100
Gypsum Sheathing Board	2'x8' Sheets	11 ga. Screws	Unblocked	4	10	75
	4'x8' Sheets	11 ga. Screws	Unblocked	7	10	100
Blocked			4	10	175	
Gypsum Wallboard	1/2	5d Cooler Nails	Unblocked	7 4	10 10	100 125
			Blocked	7 4	10 10	125 150
	5/8	6d Cooler Nails	Blocked	4	10	175
		Base ply - 6d Cooler Nails Face ply - 8d Cooler Nails	Two-ply Blocked	Base ply - 9" Face ply - 7"	10 10	250
Lumber Sheathing	5/8	8d Common Nails	Straight Sheathing	2 per Support	2 per Support	50
			Diagonal Sheathing	2 per Support	2 per Support	300

**TABLE 305P1**  
**TYPE I SHEARWALL REQUIREMENTS AT SIDEWALLS**  
 (Wind Parallel to Sidewalls)

	Maximum Length to Width Ratio (L/W)	90 mph				100 mph				110 mph			
		Fraction of Sidewall Sheathed With Shearwall Segments											
		1/4	1/2	3/4	1	1/4	1/2	3/4	1	1/4	1/2	3/4	1
		Required Shear Capacity of Sheathing Material (plf) <sup>1,2</sup>											
One Story, Top of Two Stories	1	340	170	115	85	420	210	140	105	520	260	175	130
	2	180	90	60	45	220	110	75	55	260	130	85	65
	3	120	60	40	30	140	70	45	35	180	90	60	45
	4	80	40	25	20	100	50	35	25	120	60	40	30
First Story of Two Stories	1	700	350	235	175	880	440	295	220	1060	530	355	265
	2	360	180	120	90	440	220	145	110	520	260	175	130
	3	240	120	80	60	300	150	100	75	360	180	120	90
	4	180	90	60	45	220	110	75	55	260	130	85	65

1. The values in the table above assume an 8 ft wall height. When using a wall height of 10 ft, the required shear capacity shall be increased by 25% (multiply by 1.25).
2. Required shear capacity shall be permitted to be decreased by 20% (multiply by 0.8) where the eave height is 10 ft or less.

**TABLE 305P2**  
**TYPE I SHEARWALL REQUIREMENTS AT ENDWALLS**  
 (Wind Parallel to Endwalls)

	Maximum Length to Width Ratio (L/W)	90 mph				100 mph				110 mph			
		Fraction of Endwall Sheathed With Shearwall Segments											
		1/4	1/2	3/4	1	1/4	1/2	3/4	1	1/4	1/2	3/4	1
		Required Shear Capacity of Sheathing Material (plf) <sup>1,2</sup>											
One Story, Top of Two Stories	1	220	110	75	55	280	140	95	70	340	170	115	85
	2	420	210	140	105	500	250	165	125	620	310	205	155
	3	600	300	200	150	740	370	245	185	880	440	295	220
	4	780	390	260	195	960	480	320	240	1160	580	385	290
First Story of Two Stories	1	740	370	245	185	920	460	305	230	1100	550	365	275
	2	1340	670	445	335	1640	820	545	410	2000	1000	665	500
	3	1920	960	640	480	2380	1190	795	595	2880	1440	960	720
	4	2520	1260	840	630	3120	1560	1040	780	3760	1880	1255	940

1. The values in the table above assume an 8 ft wall height. When using a wall height of 10 ft, the required shear capacity shall be increased by 25% (multiply by 1.25).
2. Required shear capacity shall be permitted to be decreased by 20% (multiply by 0.8) where the eave height is 10 ft or less.

**TABLE 305P3  
REQUIRED SHEAR CAPACITY ADJUSTMENT FACTORS**

	Maximum Unrestrained Opening Height <sup>1</sup> (Window or Door Height)				
	H/3	H/2	2H/3	5H/6	H
8' Wall Height 10' Wall Height	2'-8" 3'-4"	4'-0" 5'-0"	5'-4" 6'-8"	6'-8" 8'-4"	8'-0" 10'-0"
Fraction of Wall Sheathed with Full-Height Sheathing	Required Shear Capacity Adjustment Factors				
1/4	1.00	1.38	1.74	2.13	2.50
1/2	1.00	1.25	1.49	1.75	2.00
3/4	1.00	1.12	1.25	1.37	1.49
1	1.00	1.00	1.00	1.00	1.00

**Notes:**

1. The largest vertical dimension of any of the openings in the shearwall (between holddowns). All table values are permitted to be interpolated.
2. The sum of the length of full height sheathing in the shearwall (between holddowns) divided by the total length of the shearwall (between holddowns).

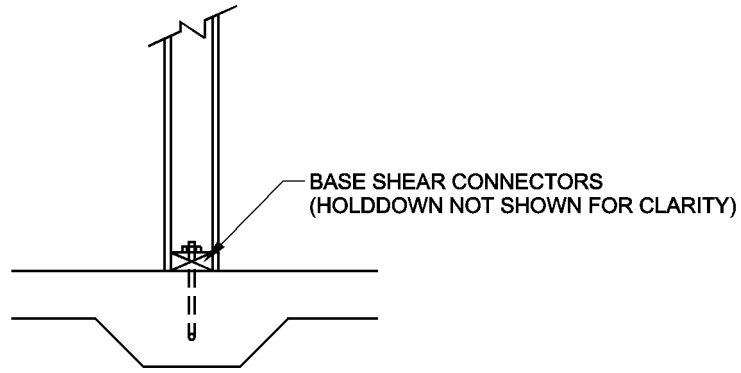
**305.5 INTERIOR SHEARWALLS**

**305.5.1 General:** Interior shearwalls which are parallel to end walls may be used to decrease the length-to-width ratio of buildings. For the purpose of determining shearwall requirements, building length shall be the distance between shearwalls which are parallel to endwalls. Interior shearwalls shall meet all the requirements and be subject to the same restrictions as exterior shearwalls and may be Type I or Type II shearwalls. Interior shearwalls shall be continuous from the foundation to the floor diaphragm and, if needed, from the floor diaphragm to the roof diaphragm. Interior shearwalls shall be connected at the foundation, second floor, and roof diaphragms (See Figures 305R1-4 and 305T1-5). The required capacity for a single interior shearwall shall be the sum of the required capacities determined from Tables 305P1 through 305P3 for each exterior wall parallel to the interior shearwall.

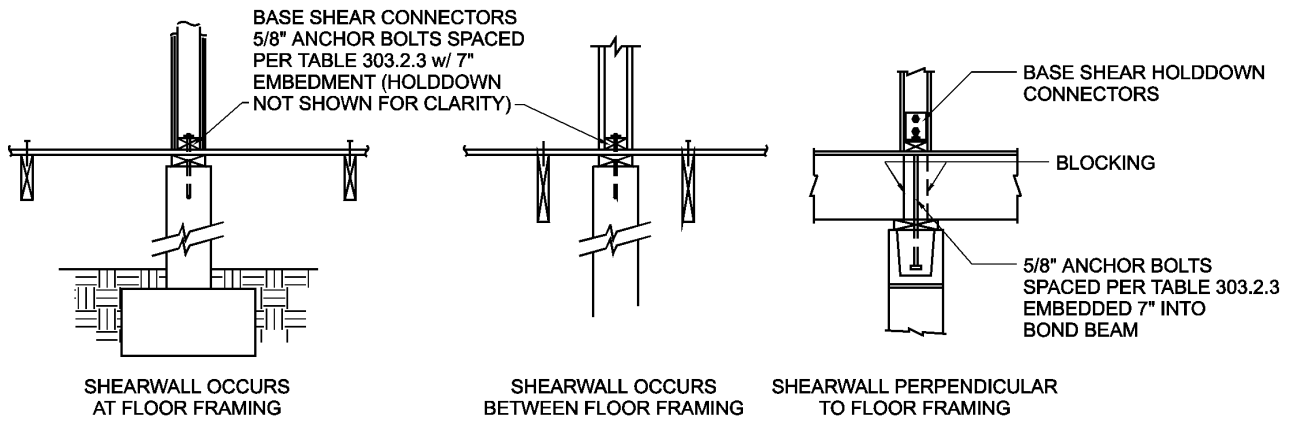
**305.5.2 Sheathing:** For interior shearwalls, sheathing shall be wood structural panels or other approved structural sheathing material. All sheathing shall be attached to framing along all four edges with joints for adjacent panels occurring over common framing members or along blocking. Sheathing shall be attached to the top member of double top plates. All nails shall be common or hot dipped galvanized box nails. The required shearwall segment length and full height sheathing length is based on the capacity of the sheathing material. Shear capacities for some common structural sheathing materials are shown in Table 305N1 and Table 305N2. The allowable shear capacity of shearwall segments sheathed on both sides with similar materials shall equal the sum of the shear capacities of each side separately.

**EXCEPTION:** The allowable shear capacity of shearwall segments sheathed with a combination of wood structural panels and gypsum wallboard on opposite sides shall equal the sum of the shear capacities of each side separately provided the wall is constructed in accordance with the following physical limitations:

1. For Type I walls, the minimum length of a shearwall segment shall be 50% of its height.
2. For Type II walls, the minimum length of full height sheathing shall be 50% of its height.

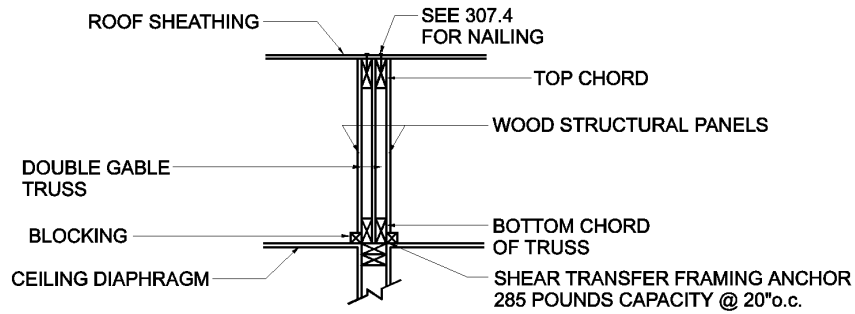


**FIGURE 305R1**  
**INTERIOR SHEARWALL TO SLAB-ON-GRADE CONNECTION**

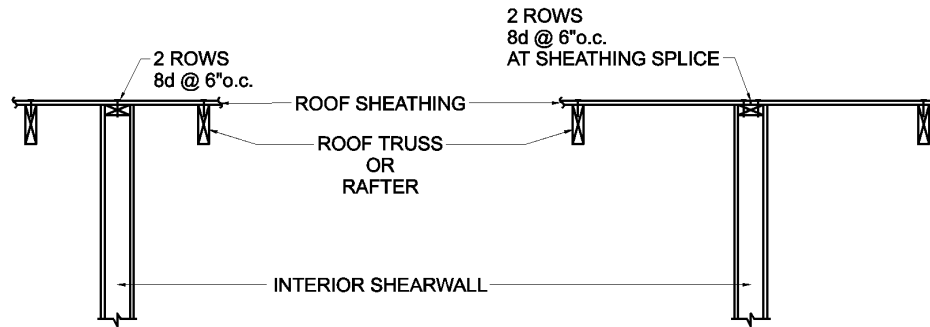


**FIGURE 305R2**  
**INTERIOR SHEARWALL TO STEMWALL FOUNDATION CONNECTION**





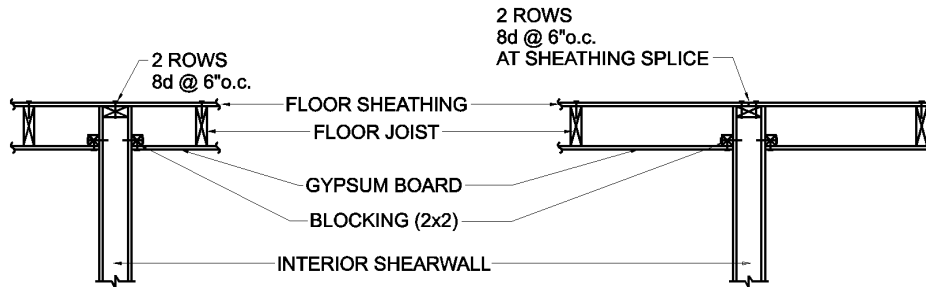
ALTERNATE METHOD WITH CEILING DIAPHRAGM



WALL OCCURS BETWEEN FRAMING

WALL OCCURS AT FRAMING  
(WALL REPLACES FRAMING)

**FIGURE 305R3**  
**INTERIOR SHEARWALL TO ROOF CONNECTION**



WALL OCCURS BETWEEN FRAMING

WALL OCCURS AT FRAMING  
(WALL REPLACES FRAMING)

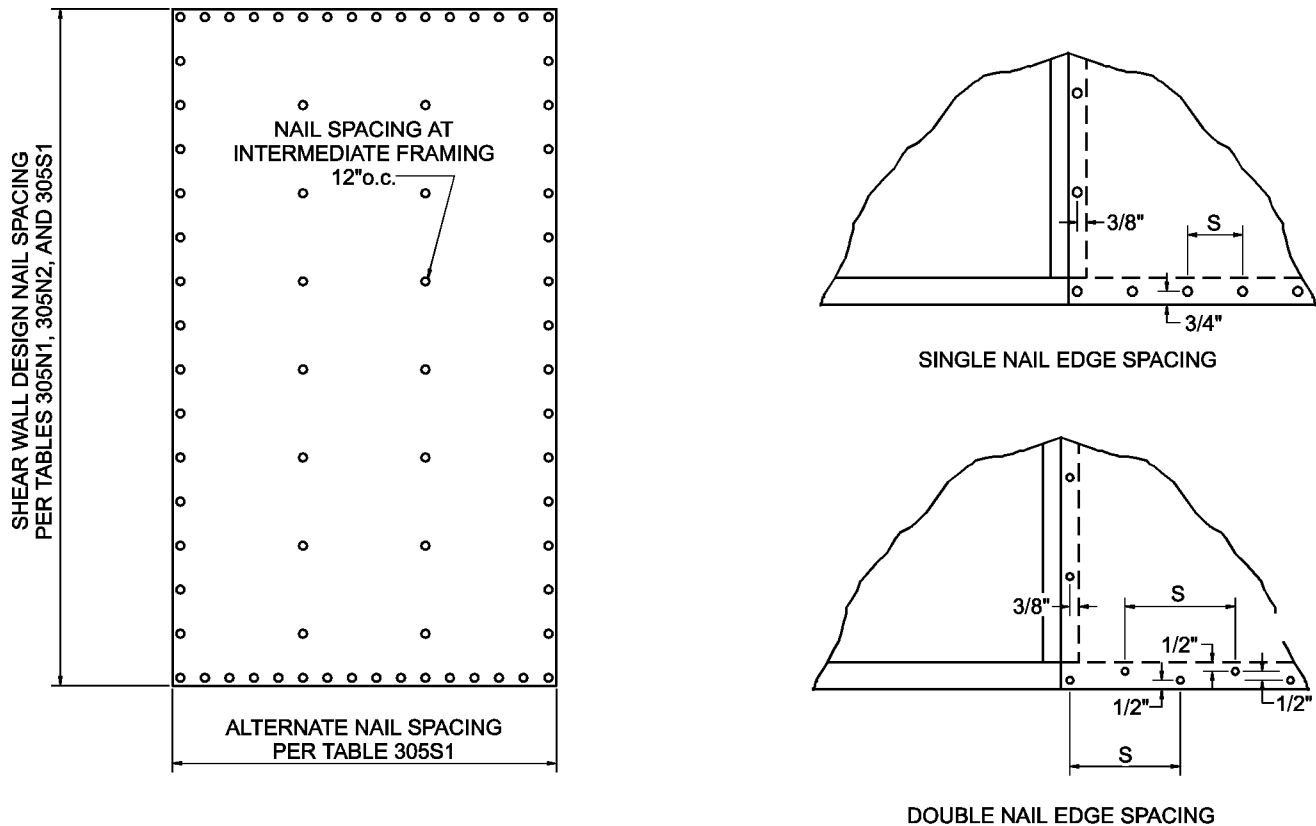
**FIGURE 305R4**  
**INTERIOR SHEARWALL TO SECOND FLOOR CONNECTION**

**305.6 WOOD STRUCTURAL PANEL SHEATHING OR SIDING USED FOR UPLIFT RESISTANCE**

**305.6.1 Wood Structural Panel Sheathing or Siding Used for Both Shearwalls and Uplift:**

Wood structural panel sheathing may be used to resist both lateral load (shearwalls) and uplift simultaneously. Shearwall requirements are determined from Tables 305P1, 2, 3, and 4, and the required shear capacity is achieved based on the framing lumber, sheathing or siding material, nails, building geometry, and nailing pattern shown in Table 305N1 or 2. When the sheathing or siding is wood structural panels, and the nail spacing at the top, bottom, and all horizontal joints of sheathing or siding panels are changed to the nail spacing shown in Table 305S1, the uplift resistance capacity of 15/32" wood structural panels shall be as shown in Table 305S1. Panels shall be of the minimum thickness required for the shearwalls but not less than 15/32" and be installed as follows:

1. Panels shall be installed with face grain parallel to studs.
2. All horizontal joints shall occur over framing and shall be attached per Table 305S1.
3. On single story construction, panels shall be attached to bottom plates and top member of the double top plate. Lowest plate shall be attached to foundation with bolts or connectors of sufficient capacity to resist the uplift forces developed in the wood structural panel sheathed or sided walls.
  - Lowest plate shall be attached to foundation with bolts or connectors of sufficient capacity to resist the uplift forces developed in the wood structural panel sheathed or sided walls.
4. On two story construction, upper panels shall be attached to the top member of the upper double top plate and to band joist at bottom of panel. Upper attachment of lower panel shall be made to band joist and lower attachment made to lowest plate at first floor framing. Lowest plate of first floor framing shall be attached to foundation with bolts or connectors of sufficient capacity to resist the uplift forces developed in the wood structural panel sheathed or sided walls.
5. Panel attachment to framing shall be as illustrated in Figure 305S1.
6. Where windows and doors interrupt wood structural panel sheathing or siding, framing anchors or connectors shall be used to resist the appropriate uplift loads.



**FIGURE 305S1  
PANEL ATTACHMENT FOR UPLIFT**

**TABLE 305S1**  
**UPLIFT CAPACITY OF 15/32" WOOD STRUCTURAL PANEL SHEATHING OR SIDING WHEN USED FOR**  
**BOTH SHEARWALLS AND UPLIFT SIMULTANEOUSLY OVER GROUP III FRAMING<sup>1</sup>**  
**(plf uplift on wall)**

	Nail Spacing Required for Shearwall Design – See Tables 305N1 and 305N2											
	6d @ 6" & 12"			8d @ 6" & 12"			8d @ 4" & 12"			10d @ 6" & 12"		
	Alternate Nail Spacing at Top and Bottom Panel Edges											
	6"	4"	3"	6"	4"	3"	6"	4"	3"	6"	4"	3"
	Uplift Capacity (plf) <sup>1</sup>											
Nails-Single Row <sup>2</sup>	0	94	189	0	118	237	N/A	0	118	0	142	285
Nails-Double Row <sup>3</sup>	189	377	566	237	474	710	118	355	592	285	570	855

1. For Group II framing divide uplift values listed in above table by 0.82.
2. Wood structural panels shall overlap the top member of the double top plate and the bottom plate by 1 1/2 inches and a single row of fasteners shall be placed 3/4" from panel edge.
3. Wood structural panels shall overlap the top member of the double top plate and the bottom plate by 1 1/2 inches. Rows of fasteners shall be 1/2 inch apart with a minimum edge distance of 1/2 inch. Each row shall have nails at the specified spacing.

### 305.6.2 Wood Structural Panel Sheathing or Siding Used for Uplift Only

Wood structural panels used for uplift only shall be 3/8-inch thick minimum and attached to top and bottom plates as described in 305.6.1. Nail spacing shall be 6" on center along vertical panel edges and 12" on center at intermediate framing. Nail spacing at horizontal panel joints shall be 6", 4", or 3" on center, single row or double row. See Table 305S2 for allowable uplift values for each condition. (See Figure 305S1 for illustration of attachment pattern.) NOTE: These uplift values may not be used in any shearwall segment.

**TABLE 305S2**  
**UPLIFT CAPACITY OF 3/8" MINIMUM WOOD STRUCTURAL PANEL SHEATHING**  
**OR SIDING OVER GROUP III FRAMING<sup>1</sup>**  
**(plf uplift on wall)**

	6d Nails			8d Nails			10d Nails		
	Nail Spacing at Top and Bottom Panel Edges								
	6"	4"	3"	6"	4"	3"	6"	4"	3"
	Uplift Capacity (plf)								
Single Row of Nails <sup>2</sup>	189	286	377	237	355	474	285	431	570
Double Row of Nails <sup>3</sup>	377	566	763	474	710	958	570	855	1153

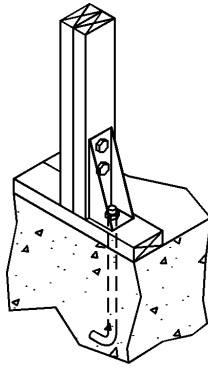
1. For Group II framing, divide uplift values listed in above table by 0.82.
2. Wood structural panels shall overlap the top member of the double top plate and the bottom plate by 1 1/2 inches and a single row of fasteners shall be placed 3/4" from panel edge.
3. Wood structural panels shall overlap the top member of the double top plate and the bottom plate by 1 1/2 inches. Rows of fasteners shall be 1/2 inch apart with a minimum edge distance of 1/2 inch. Each row shall have nails at the specified spacing.

**305.7 HOLDDOWN CONNECTORS**

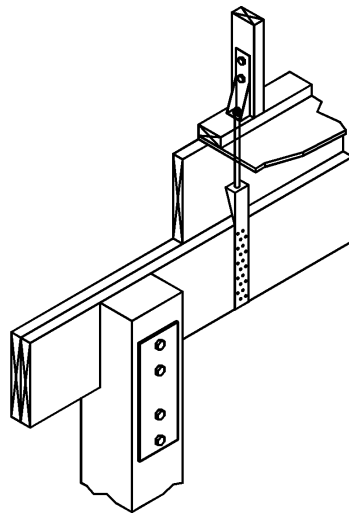
Exterior and interior shearwalls require holddowns to resist the overturning moment in shearwall segments in addition to the requirement for uplift resistance specified in 305.3. Where holddowns are required by Section 305.4.1 they shall be fastened to or through doubled studs and be connected to the foundation with a continuous connection or load path in accordance with the manufacturer's recommendations. The total design load for each holddown shall be at least 8 times the tabulated shear capacity value in Tables 305P1, 305P2, 305P3, and 305P4 for 8 foot walls and 10 times the tabulated shear capacity value for 10 foot walls (See Figures 305T1-5). Where holddowns of first and second-story shearwalls align vertically, the total holddown force at the bottom of the first-story shearwall will be the total of the first- and second-story shearwall holddown forces. A holddown connector shall be provided at the end of each shearwall segment for Type I shearwalls and at the end of each shearwall for Type II shearwalls.

**EXCEPTION:** A single holddown shall be permitted at building corners where two shearwalls or shearwall segments meet, provided the following conditions are met:

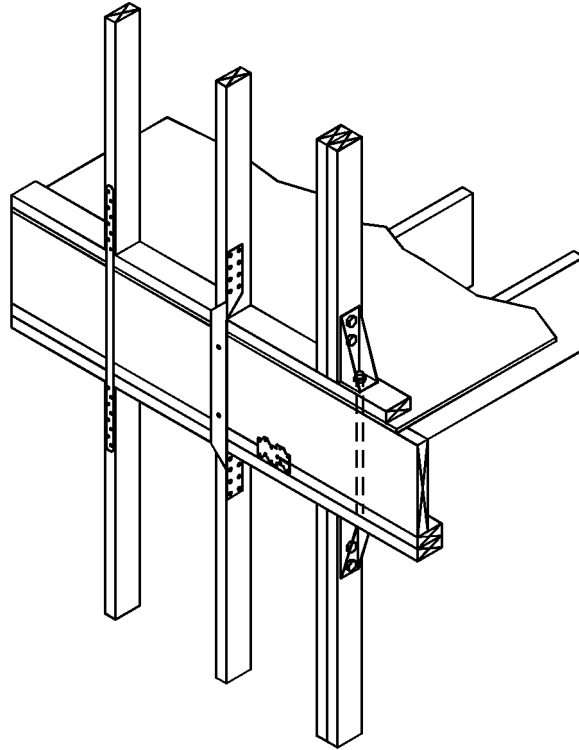
1. The holddown shall be sized for the greater of the required holddown design load of each of the shearwalls or shearwall segments that meet at a building corner.
2. The holddown shall be located on the wall where it can be fastened to or through multiple studs.
3. The corner studs where the shearwalls or shearwall segments meet shall be tied together so that the overturning force from the perpendicular wall is transferred to the holddown on the adjacent wall. Provide 16d common nails at 6" o.c. along the studs when the maximum holddown force does not exceed 3070 pounds. When the required holddown force on the wall without the holddown exceeds 3070 pounds, provide an additional 16d nail for each 192 pounds above 3070 pounds. (See Figure 305T6.)



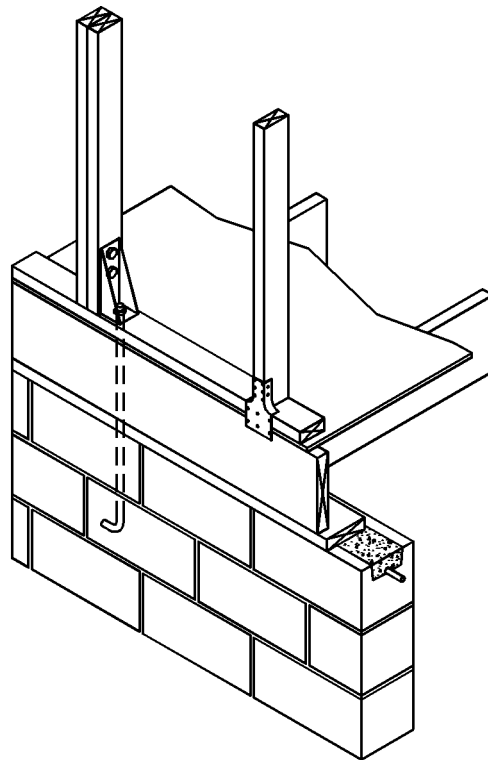
**FIGURE 305T1  
HOLDDOWN INSTALLATION AT SLAB-ON-GRADE FOUNDATION**



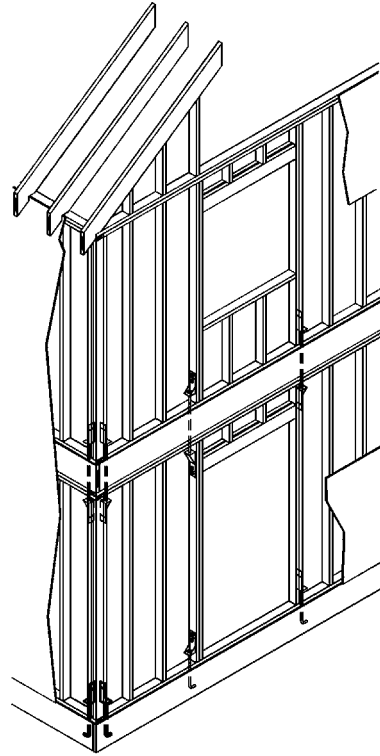
**FIGURE 305T2  
TYPICAL HOLDDOWN INSTALLATION AT PILE FOUNDATION**



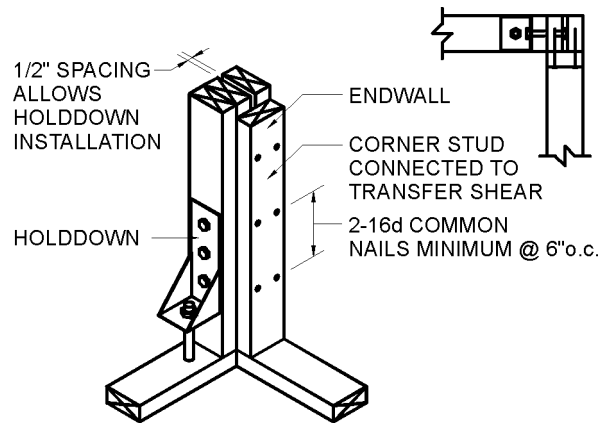
**FIGURE 305T3**  
**FIRST STORY TO SECOND STORY HOLDDOWN INSTALLATION**



**FIGURE 305T4**  
**HOLDDOWN INSTALLATION AT FOUNDATION WALL**



**FIGURE 305T5  
HOLDDOWN INSTALLATION AT SHEARWALLS AND OPENINGS**



**FIGURE 305T6  
SINGLE HOLDDOWN AT CORNERS**

## 306 CEILING SYSTEMS

### 306.1 CEILING FRAMING

**306.1.1 Rafter-Joist System:** Ceiling joists shall be in accordance with the American Forest and Paper Association (AF&PA's) Span Tables for Joists and Rafters. The ceiling joists shall be installed parallel to the rafters. Ceiling joists shall be fastened in accordance with Table 2306.1 of the Standard Building Code. Notches and holes shall be in accordance with Section 2309.1.8 of the Standard Building Code.

**306.1.2 Wood I-Joist Systems:** Single or continuous span I-joists shall comply with the manufacturer's code evaluation report.

**306.1.3 Truss Systems:** See 307.2.

### 306.2 CEILING DIAPHRAGMS

**306.2.1** In those cases where a gable endwall is not built using full-height studs continuous from the uppermost floor to the underside of the roof, an attic floor or ceiling diaphragm shall be used to resist the lateral loads at the horizontal joint between the top plate of a platform-framed endwall and the gable construction above. Where there is no attic floor or ceiling diaphragm at that height, such as a cathedral ceiling condition, the entire endwall, including the gable, shall be constructed using full length studs from the uppermost floor to the underside of the roof (See 305.2.2 and Figure 305J).

**306.2.2** A ceiling diaphragm is not required with a hipped roof.

### 306.3 DIAPHRAGM MATERIALS

**306.3.1 Gypsum Wallboard:** Where a gypsum board ceiling is used to create the required diaphragm, the diaphragm length shall be a minimum of two times the width of the building. The gypsum board shall be a minimum of 1/2 inch thick and be fastened directly to the ceiling joists or bottom chords of trusses (no furring) with 5d cooler nails, or GWB-54 1 1/2-inch nails installed 10 inches on center in the board field and 7 inches on center at the board ends and ceiling edges. The ceiling diaphragm shall be continuous or shall be spliced with framing around the top plates of partition walls with 5d cooler nails or GWB-54 1 1/2 inch nails at 7 inches on center. The ceiling diaphragm shall be fastened to 2x perimeter blocking members which are fastened to the top plates with 10d nails at 6 inches on center (See Figures 305K, 306H, or 306I). Lateral bracing shall be installed on the tops of ceiling joists, or truss bottom chords, at a spacing of not greater than 6 feet. The lateral bracing shall be a minimum of 2x4 lumber extending inward from the gable end a minimum of 8 feet and fastened to each truss, or ceiling joist, and the gable end with a minimum of two 10d common or hot-dipped galvanized box nails. A minimum of 2x4 lumber blocking shall be installed in the first truss, or joist space directly below, and attached to the lateral brace with a minimum of four 10d common or hot-dipped galvanized box nails. A minimum of one inch wide 16 gauge steel strap shall be fastened lengthwise over the top of each lateral brace, and to the endwall studs in accordance with Table 306G (See Figure 306H).

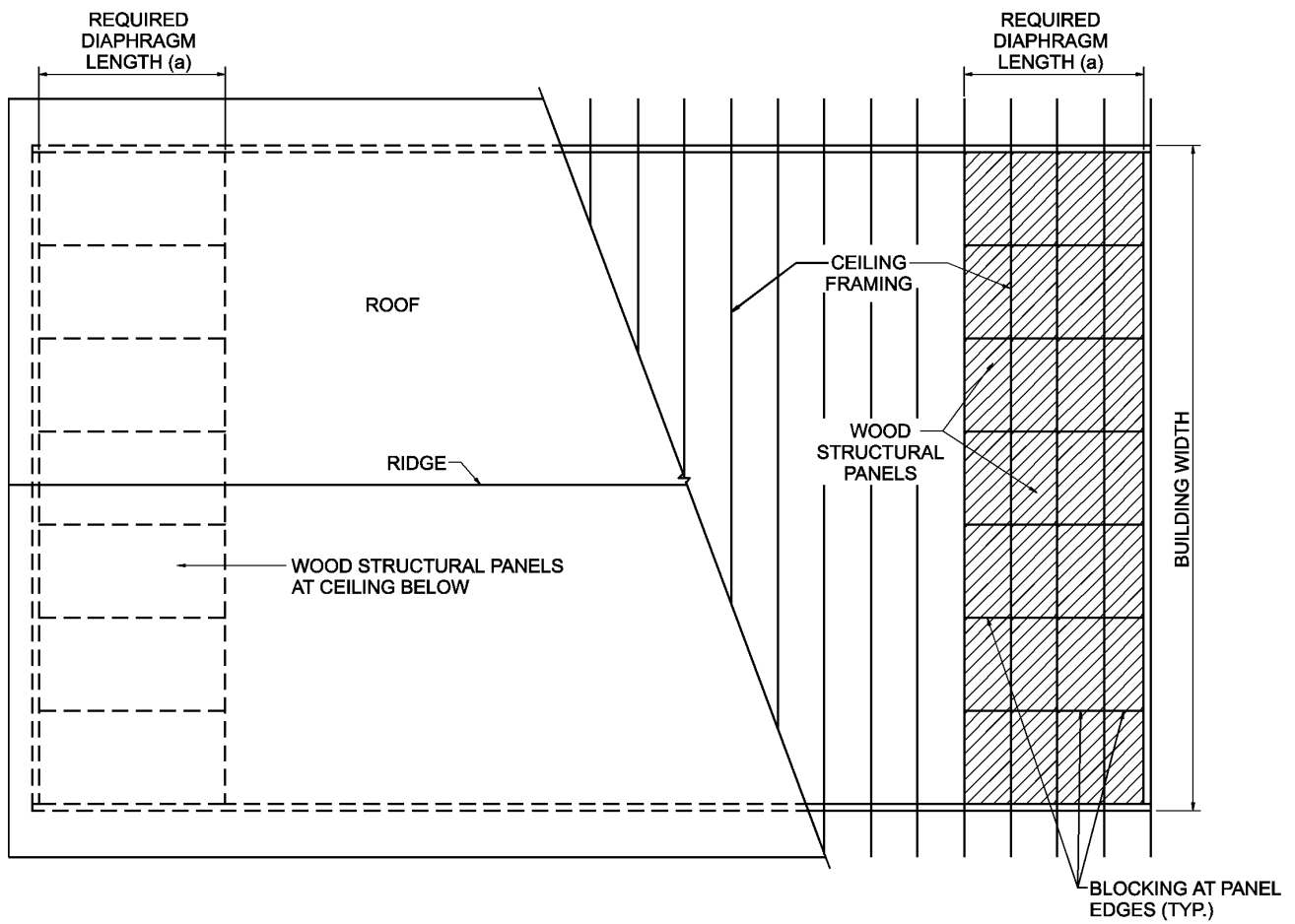
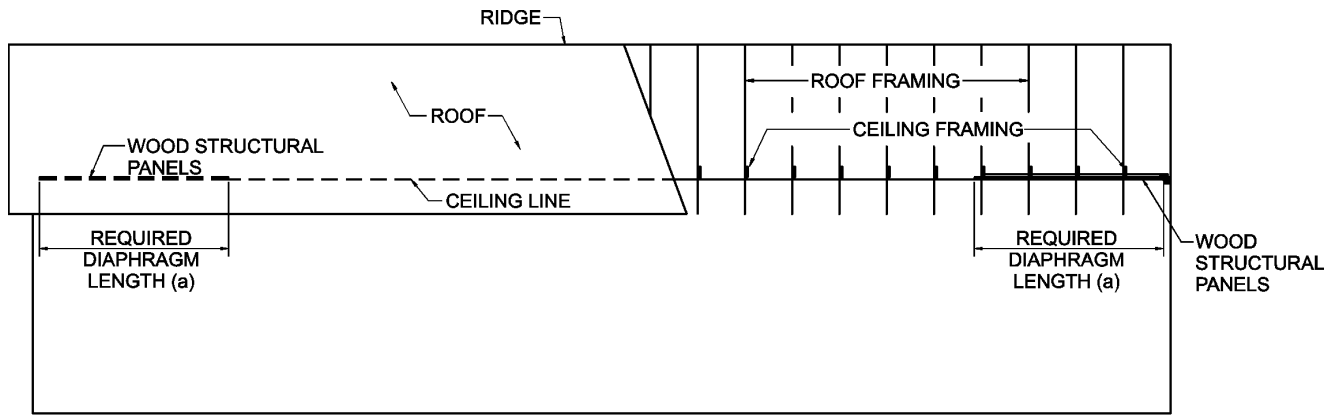
**306.3.2 Wood Structural Panels:** Where wood structural panels are used to create the required diaphragm, the diaphragm is necessary at each endwall, and each diaphragm length shall be as shown in Table 306A for the building widths and eave heights given. The panels shall be 15/32" thick minimum. Blocking and diaphragm chords shall be 2x4 or larger, Group III species lumber, grade #2, or better. When truss framing is used, bottom chord of truss shall NOT be used as a diaphragm chord or as blocking (See Figures 306B, C, and D).

1. Chords are required at both diaphragm edges parallel to the endwall. Chords shall be one piece for the full width of the building or shall be spliced in accordance with Table 306A.
2. Blocking is required at all panel joints and all edges at sidewalls. Blocking may be installed flatwise.
3. Wood structural panels shall be fastened to framing, chords, and blocking with 8d common or 8d hot-dipped galvanized box nails. Nail spacing at ceiling framing shall be 12" o.c. max. Nail spacing at chords and blocking shall be as shown in Table 306A.
4. Nails for chord splicing and for fastening chords and blocking to wall framing shall be 10d common or 10d hot-dipped galvanized box nails. The number of nails required for each side of each chord splice shall be as shown in Table 306A. Nails shall be spaced to avoid splitting of wood. Diaphragm chords shall be nailed to top plate of walls at 4" o.c. at side walls and 6" o.c. at end walls.
5. Finish ceiling material may be applied over the wood structural panel diaphragm and over the ceiling framing throughout the remainder of the building with or without furring. This ceiling material is not a part of the diaphragm requirement.

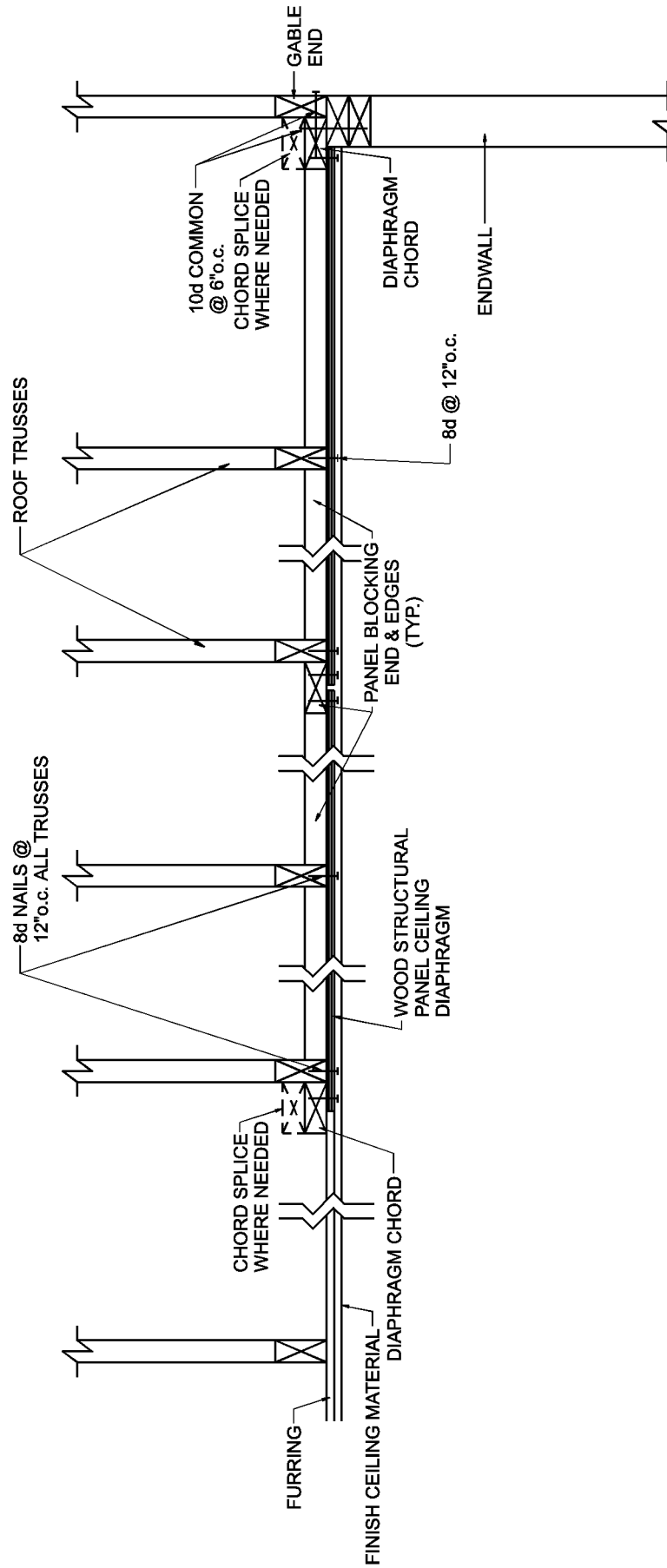
**TABLE 306A  
WOOD STRUCTURAL PANELS CEILING DIAPHRAGM**

Building Width (ft)	90 MPH			100 MPH			110 MPH		
	Diaphragm Length (a) (ft)	8d Fastener Spacing at Chords and Blocking (in.)	10d Chord Splice (# Fasteners ea. side)	Diaphragm Length (a) (ft)	8d Fastener Spacing at Chords and Blocking (in.)	10d Chord Splice (# Fasteners ea. side)	Diaphragm Length (a) (ft)	8d Fastener Spacing at Chords and Blocking (in.)	10d Chord Splice (# Fasteners ea. side)
<b>CRAWL SPACE OR SLAB-ON-GRADE – ONE STORY (Eave heights up to 15 feet)</b>									
24	4	4	15	8	6	10	8	6	12
36	8	4	19	8	4	24	12	4	19
44	12	6	21	12	4	25	16	6	23
52	12	4	31	16	4	28	16	4	34
60	16	4	33	16	4	40	20	4	39
<b>CRAWL SPACE OR SLAB-ON-GRADE – TWO STORY (Eave heights 15-30 feet)</b>									
24	8	6	9	8	6	11	8	4	13
36	8	4	22	12	6	18	12	4	22
44	12	4	24	12	4	29	16	4	27
52	12	4	35	16	4	33	20	4	32
60	16	4	38	20	4	37	24	4	37
<b>WOOD PILING – ONE STORY (Eave heights up to 18 feet)</b>									
24	8	6	8	8	6	11	8	6	12
36	8	4	21	12	6	17	12	4	21
44	12	6	22	12	4	27	16	4	25
52	12	4	33	16	4	30	20	4	30
60	16	4	35	20	4	34	20	4	42
<b>WOOD PILING – TWO STORY (Eave heights 18-30 feet)</b>									
24	8	6	9	8	6	12	8	4	14
36	8	4	23	12	4	19	12	4	23
44	12	4	25	12	4	30	16	4	28
52	16	6	28	16	4	34	20	4	33
60	16	4	39	20	4	39	24	4	39

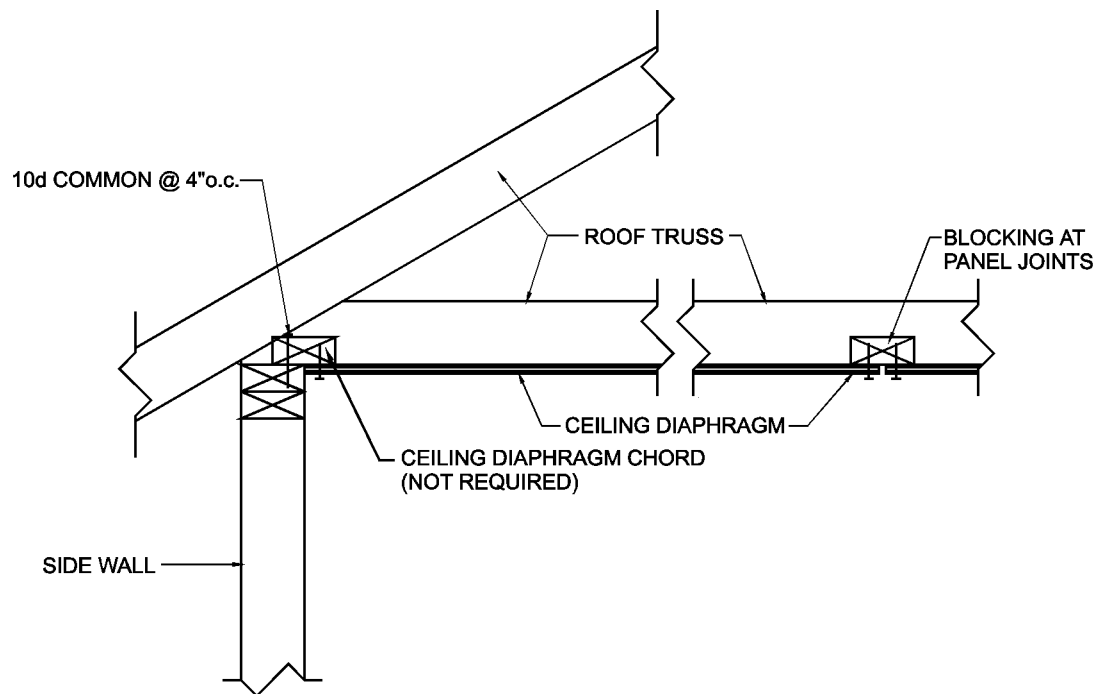




**FIGURE 306B**  
**WOOD STRUCTURAL PANELS CEILING DIAPHRAGM**



**FIGURE 306C**  
**WOOD STRUCTURAL PANELS CEILING DIAPHRAGM SECTION PARALLEL TO RIDGE**  
**ATTACHMENT TO ENDWALL**



**FIGURE 306D**  
**WOOD STRUCTURAL PANEL CEILING DIAPHRAGM SECTION PERPENDICULAR TO**  
**RIDGE ATTACHMENT TO SIDEWALL**

### 306.4 DIAPHRAGM ALTERNATIVES

**306.4.1** Other sheathing/ceiling materials, fastening methods, and length-to-width ratios may be used to create the required diaphragm. Such alternative diaphragms shall develop the shear capacities given in Table 306E. Shear capacities for some common sheathing materials are given in Tables 304C1 and 304C2.

**TABLE 306E  
REQUIRED CEILING DIAPHRAGM CAPACITIES**

Roof Angle (degrees)		Maximum Length of Ceiling		Building Width														
				24'	36'	44'	52'	60'	24'	36'	44'	52'	60'	24'	36'	44'	52'	60'
				Required Shear Capacity of Sheathing Material (plf)														
		90 mph				100 mph				110 mph								
0	W	60	55	55	55	55	75	70	70	70	70	90	85	85	85	85		
	2W	30	30	30	30	30	40	35	35	35	35	45	45	45	45	45		
	3W	20	20	20	20	20	25	25	25	25	25	30	30	30	30	30		
	4W	15	15	15	15	15	20	20	20	20	20	25	20	20	20	20		
10	W	65	65	70	70	75	80	80	85	85	90	100	100	100	105	110		
	2W	35	35	35	35	40	40	40	45	45	45	50	50	50	55	55		
	3W	20	20	25	25	25	25	25	30	30	30	35	35	35	35	35		
	4W	15	15	20	20	20	20	20	20	20	25	25	25	25	25	30		
20	W	75	75	80	85	90	90	95	100	105	110	110	115	120	125	135		
	2W	40	40	40	45	45	45	50	50	55	55	55	60	60	65	70		
	3W	25	25	25	30	30	30	30	35	35	35	35	40	40	40	45		
	4W	20	20	20	20	25	25	25	25	25	30	30	30	30	30	35		
30	W	80	90	95	100	110	100	110	115	125	135	120	130	140	150	160		
	2W	40	45	50	50	55	55	55	60	65	70	60	65	70	75	80		
	3W	25	30	30	35	35	35	35	40	40	45	40	45	45	50	55		
	4W	20	25	25	25	30	25	30	30	30	35	30	35	35	40	40		

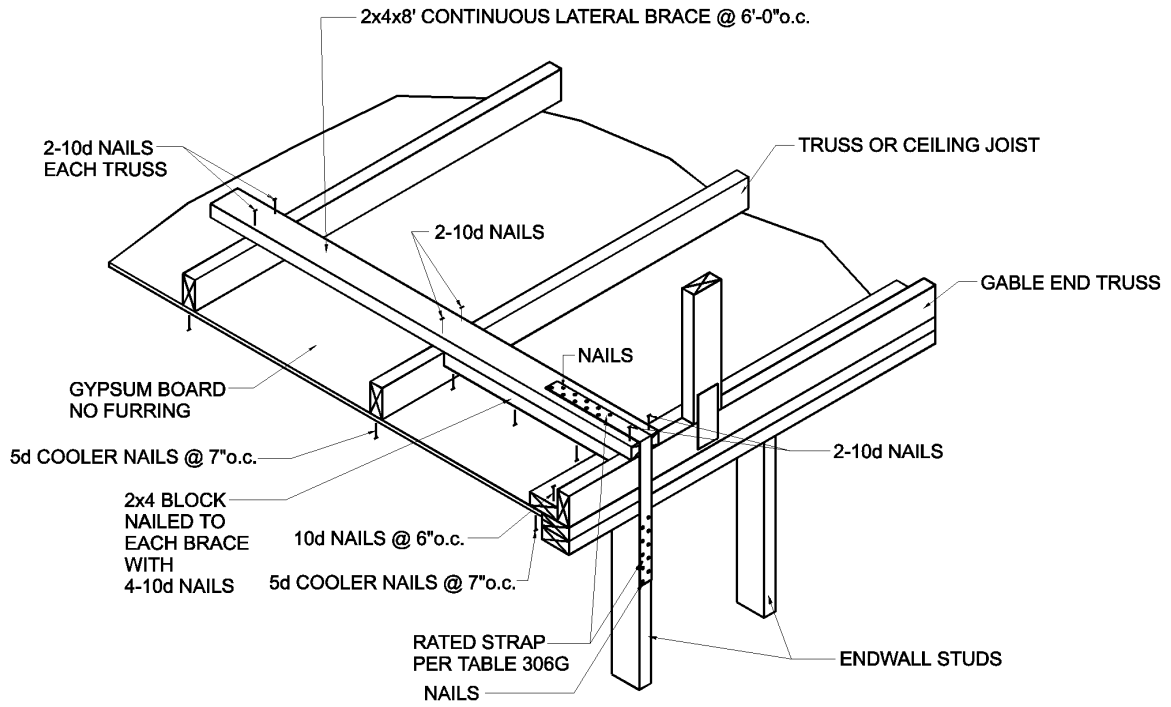
W = Building Width

**306.4.2** Gable endwalls shall be connected to alternative ceiling diaphragms in accordance with Table 306G and Figure 306H.

**TABLE 306G  
REQUIRED ENDWALL CONNECTION CAPACITIES**

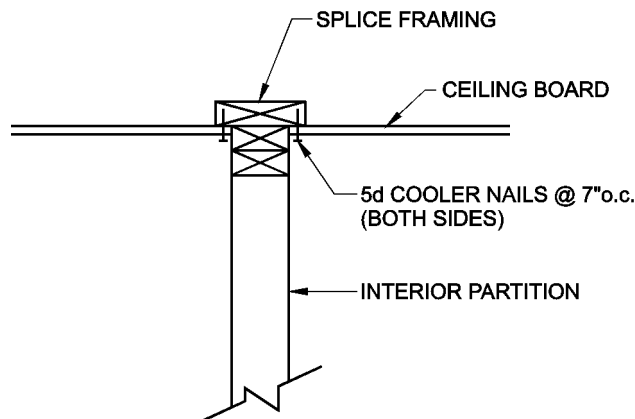
Roof Angle (degrees)		Building Width														
		24'	36'	44'	52'	60'	24'	36'	44'	52'	60'	24'	36'	44'	52'	60'
		Required Endwall Connection Capacities (plf)														
		90 mph				100 mph				110 mph						
0		80	75	75	75	75	95	90	90	90	90	115	110	110	110	110
10		85	85	90	90	95	105	105	110	110	115	130	130	130	135	140
20		95	100	105	110	115	115	120	130	135	140	140	145	155	165	170
30		105	115	120	130	140	130	140	150	160	170	155	170	180	195	205

W = Building Width



1. SIZE AND NUMBER OF NAILS IN STRAP AS REQUIRED FOR LOAD GIVEN IN TABLE 306G.

**FIGURE 306H**  
**CEILING CONNECTION TO GABLE ENDWALL**  
**FOR GYPSUM BOARD DIAPHRAGMS**



**FIGURE 306I**  
**GYPSUM BOARD DIAPHRAGM SPLICE**  
**OVER PARTITION**

## 307 ROOF SYSTEMS

### 307.1 RAFTER-JOIST FRAMING SYSTEMS

**307.1.1 Rafters:** Rafters shall be sized in accordance with AF&PA's Span Tables for Joists and Rafters using accepted dead and live load conditions. Spacing shall be 24" o.c. maximum.

**307.1.2 Substitutions:** Where a specific species and grade is given in tables in this Standard, a species and grade with equivalent or greater design values shall be permitted. Design values contained in Design Values for Wood Construction, a supplement to the National Design Specification for Wood Construction, shall be used to determine equivalence of substituted material.

**307.1.3 Ridge Board:** A ridge board is required for rafters. The ridge board shall be minimum 2-inch nominal thickness and not less in depth than the depth cut of the rafter. The rafters shall be placed directly opposite each other and bear against the ridge board.

**307.1.4 Collar Beams:** A 1x6 collar beam shall be nailed in the upper third of the roof to every third pair of rafters. Notches and holes shall be in accordance with Section 2309.1.8 of the Standard Building Code.

**307.1.5 Connections:** Uplift connectors shall be provided at rafter bearing to resist the uplift loads in Table 307A. The uplift load requirements may be interpolated for intermediate building widths. Uplift connection may be from rafter to plate or from rafter to stud (See Figure 307D). In addition, the rafter shall be fastened to the wall in accordance with Table 2306.1 of the Standard Building Code (See Appendix E). Framing anchors designed to carry horizontal load may be substituted for toe nails specified in Table 2306.1 of the Standard Building Code (See Appendix E). In addition to uplift loads, connections shall be capable of resisting 150 lb of lateral load parallel and perpendicular to the wall for roof members spaced 12 inches on center, 200 lb for roof members spaced 16 inches on center, and 300 lb for roof members spaced 24 inches on center.

### 307.2 TRUSS FRAMING SYSTEMS

**307.2.1 Trusses:** Trusses shall be designed in accordance with the TPI Design Specification for Metal Plate Connected Wood Trusses.

**307.2.2 Parallel chord roof trusses:** Truss design submittals shall be in accordance with TPI Design Specifications for Metal Plate Connected Parallel Chord Wood Trusses.

**307.2.3 Truss design submittals** shall indicate design wind speed, height above ground, and amount of uplift at bearings.

**307.2.4 Truss Spacing:** Metal plate connected wood trusses shall be spaced no more than 24 inches on center and designed for live loads and wind loads for an enclosed building based on Section 1606 of the Standard Building Code.

**307.2.5 Girder trusses:** Where appropriate, girder trusses shall be designed to function also as drag struts. Truss design submittals and erection instructions shall show both uplift and lateral connection load requirements at ends of girder truss. Drag strut requirements can be calculated by multiplying the span of the strut by the appropriate roof diaphragm capacity given in Tables 307H1 and 307H2.

**307.2.6 Connections:** Uplift connectors shall be provided at truss bearing to resist the uplift loads in Table 307A. The uplift load requirements may be interpolated for intermediate building widths. Uplift connection may be from truss to plate or from truss to stud (See Figures 305G1, 305G2, and 307E). In addition to uplift loads, connections shall be capable of resisting 150 lb of lateral load parallel and perpendicular to the wall for roof members spaced 12 inches on center, 200 lb for roof members spaced 16 inches on center, and 300 lb for roof members spaced 24 inches on center.

**307.2.7 Hipped Roofs:** Where trusses are used to form a hipped roof, a step-down hip system shall be used (See Figure 307C). Uplift connections at bearing of hip trusses may be determined by using Table 307B. This method is for a step down hip system only. Truss to truss connections shall be part of the truss design.

### 307.3 BRACING

**307.3.1** When a gable endwall extends from the uppermost floor to the roof sheathing and is not supported by a ceiling diaphragm, endwall roof bracing shall be provided perpendicular to the rafters or trusses in the first two rafter or truss spaces at each end and shall be spaced at 4 ft maximum on center as shown in Figure 307F. Bracing members shall be full depth of rafters or truss top chords. Roof sheathing shall be attached to bracing with panel-end nailing recommendations.

**TABLE 307A**  
**WIND UPLIFT LOADS AT TOP OF SIDEWALL**  
(Pounds per Truss/Rafter)

Roof & Ceiling Dead Load <sup>1</sup>	90 mph					100 mph					110 mph				
	Building Width														
	24'	36'	44'	52'	60'	24'	36'	44'	52'	60'	24'	36'	44'	52'	60'
	<b>Uplift Loads for 12" truss/rafter spacing</b>														
5 psf	310	445	535	630	720	400	570	690	810	930	500	715	860	1005	1155
7 psf	285	405	485	570	655	370	530	640	750	865	470	675	810	950	1090
10 psf	240	345	415	490	560	330	470	570	670	770	430	615	740	870	995
15 psf	170	245	295	350	400	260	370	450	530	610	360	515	620	725	835
20 psf	100	145	175	210	240	190	270	330	390	450	290	415	500	585	675
25 psf	30	45	55	70	80	120	170	210	250	290	220	315	380	445	515
	<b>Uplift Loads for 16" truss/rafter spacing</b>														
5 psf	415	595	715	835	960	535	765	920	1075	1235	665	950	1145	1340	1540
7 psf	375	540	650	760	875	495	710	855	1000	1150	625	900	1080	1265	1455
10 psf	320	460	555	650	750	440	630	760	890	1025	570	820	985	1155	1330
15 psf	230	325	395	465	535	345	495	600	705	810	480	685	825	970	1115
20 psf	135	195	235	275	320	255	365	440	515	595	385	550	665	780	900
25 psf	40	60	75	90	110	160	230	280	330	385	290	420	505	595	690
	<b>Uplift Loads for 24" truss/rafter spacing</b>														
5 psf	620	890	1070	1255	1440	800	1145	1380	1615	1855	995	1425	1720	2015	2310
7 psf	565	810	975	1145	1315	745	1065	1280	1505	1725	940	1345	1620	1900	2185
10 psf	480	690	830	975	1120	660	945	1140	1335	1535	855	1225	1480	1735	1990
15 psf	340	490	590	695	800	520	745	900	1055	1215	715	1025	1240	1455	1670
20 psf	200	290	350	415	480	380	545	660	775	890	575	895	1000	1175	1350
25 psf	60	90	110	135	160	240	345	420	495	575	435	625	760	895	1030

**Notes:**

1. Individual connector ratings shall not be less than 100 lbs for uplift.
2. Roof and ceiling dead loads shall be actual loads provided, not counting the roof covering. In the absence of more accurate data, the following roof and ceiling dead loads shall be used: 7 psf for truss assembly (roof sheathing, trusses, gypsum ceiling); 7 psf for rafter assembly (roof sheathing, rafters, gypsum ceiling); 10 psf for rafter/ceiling assembly (roof sheathing, rafters and ceiling joists connected as per Table 2306.1 of the Standard Building Code).  
EXCEPTION: Where roof tile is installed in accordance with the SBCCI Standard for Determining the Wind Resistance of Concrete and Clay Roof Tile, the actual weight of the tile shall be permitted to be included in the total roof and ceiling dead load.
3. The following adjustments shall be permitted (uplift shall not be less than 100 lbs per connector after adjustment):
  - a. The required uplift capacity shall be permitted to be reduced by 30% (multiply by 0.70) for connections at least W/5 from corners but not less than 6 feet.
  - b. The values in the tables assume a maximum eave height of 30 ft. When the eave height is 12 ft or less, the values shall be permitted to be reduced by 20% (multiply by 0.80).
  - c. Footnote 3b shall be permitted to be applied simultaneously with footnote 3a.

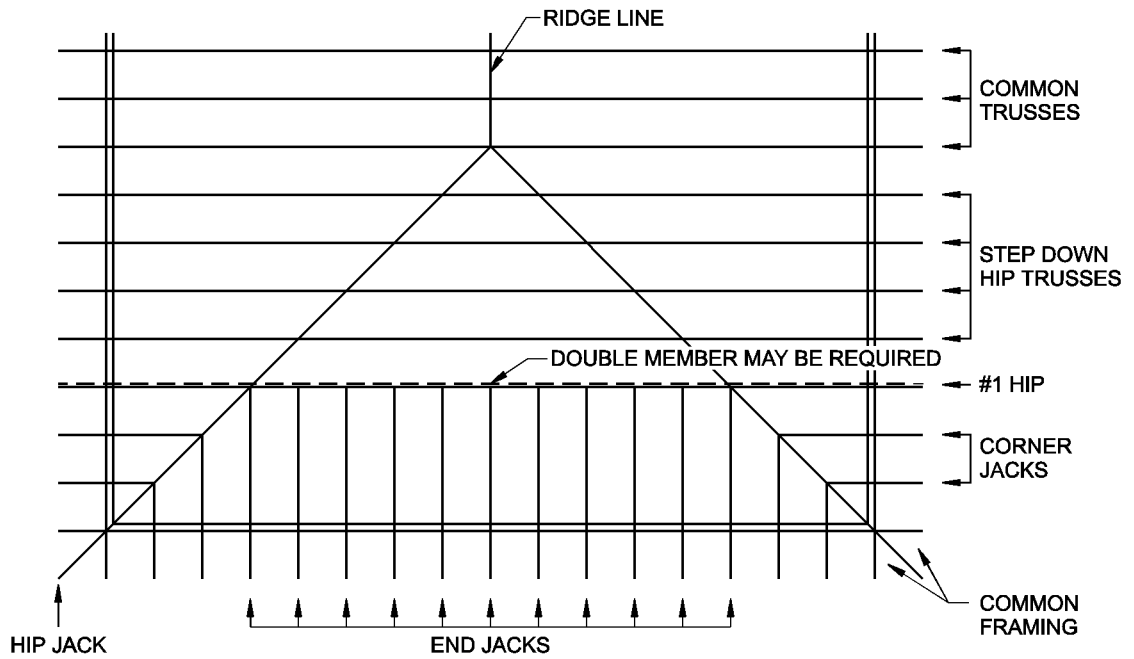
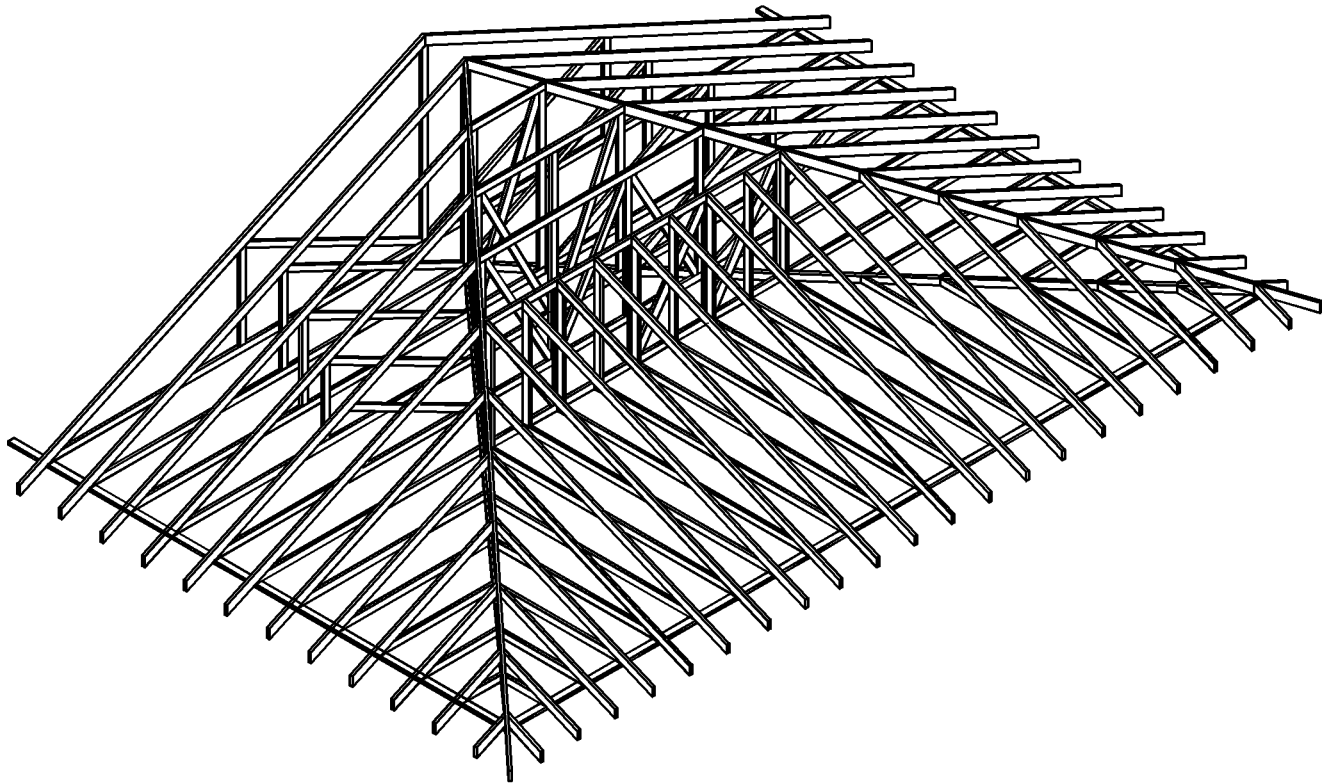
**TABLE 307B**  
**HIP ROOF STEP DOWN SYSTEM**  
**UPLIFT LOADS AT BEARING (lbs)**

Hip Truss Member	From Table 307A Find the Uplift Load For:	For 7-ft Endjack System	For 11-ft Endjack System
		Multiply Uplift Load By	
Endjacks	24' Building Width	0.68	0.68
Cornerjacks	24' Building Width	0.75	0.85
Hipjack	24' Building Width with Trusses @ 24" o.c.	1	1.1
#1 Hip Truss	Actual Building Width with Trusses @ 24" o.c.	1.8	2

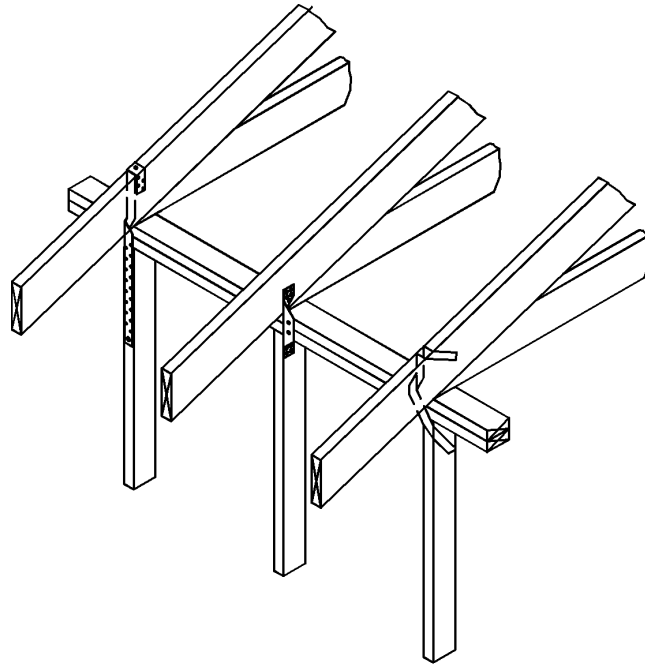
**Notes:**

1. Individual connector ratings shall not be less than 100 lbs for uplift.
2. Roof and ceiling dead loads shall be actual loads provided, not counting the roof covering. In the absence of more accurate data, the following roof and ceiling dead loads shall be used: 7 psf for truss assembly (roof sheathing, trusses, gypsum ceiling); 7 psf for rafter assembly (roof sheathing, rafters, gypsum ceiling); 10 psf for rafter/ceiling assembly (roof sheathing, rafters and ceiling joists connected per Table 2306.1 of the Standard Building Code).  
EXCEPTION: Where roof tile is installed in accordance with the SBCCI Standard for Determining the Wind Resistance of Concrete and Clay Roof Tile, the actual weight of the tile shall be permitted to be included in the total roof and ceiling dead load.
3. The following adjustments shall be permitted (uplift shall not be less than 100 lbs per connector after adjustment):
  - a. The required uplift capacity shall be permitted to be reduced by 30% (multiply by 0.70) for connections at least W/5 from corners but not less than 6 feet.
  - b. The values in the tables assume a maximum eave height of 30 ft. When the eave height is 12 ft or less, the values shall be permitted to be reduced by 20% (multiply by 0.80).
  - c. Footnote 3b shall be permitted to be applied simultaneously with footnote 3a.

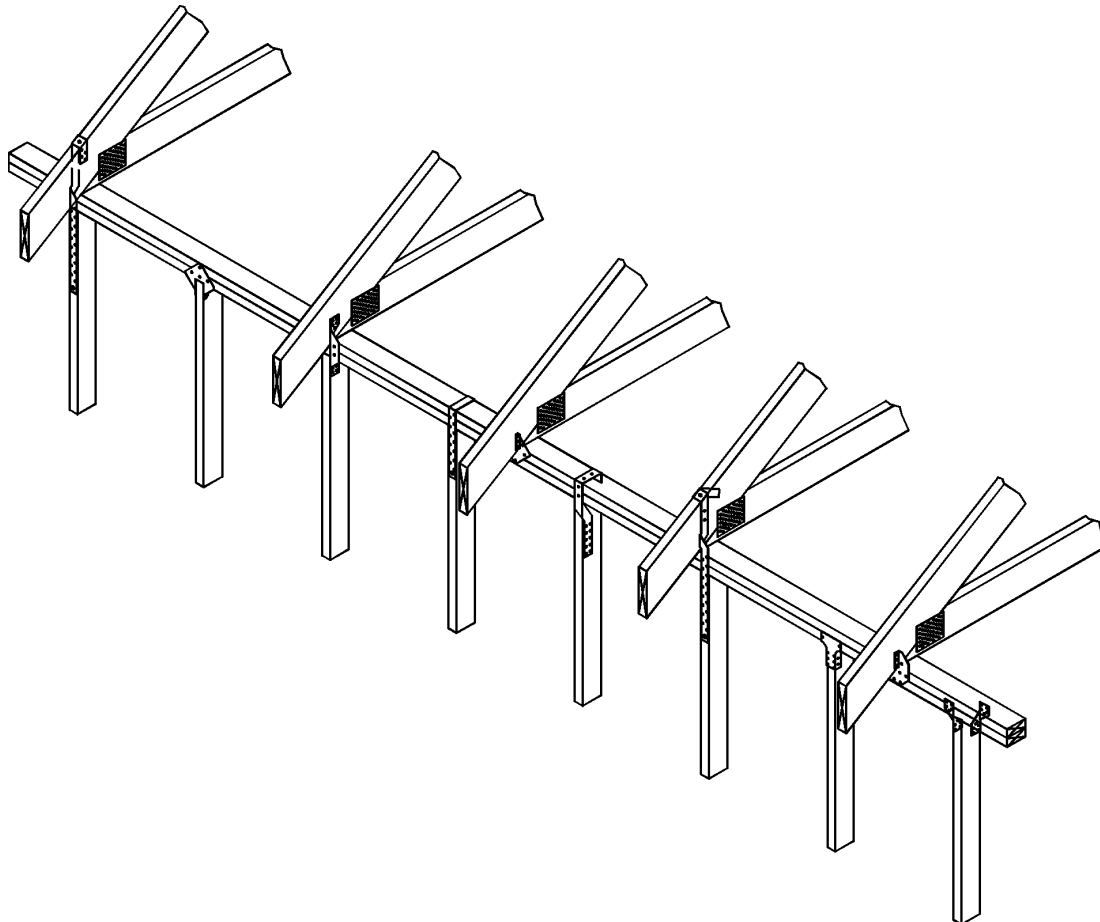




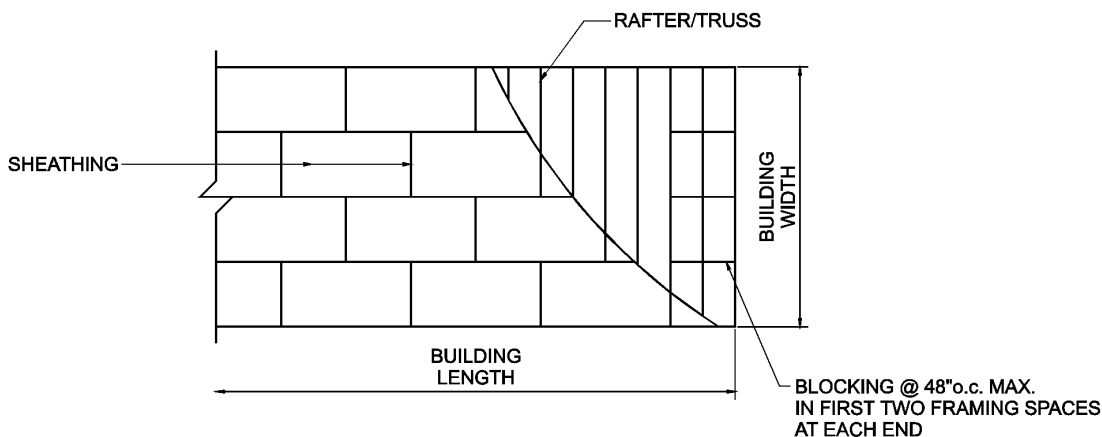
**FIGURE 307C**  
**HIP ROOF FRAMING USING TRUSSES**



**FIGURE 307D**  
**RAFTER TO TOP PLATE**  
**TO STUD CONNECTION**



**FIGURE 307E**  
**TRUSS TO TOP PLATE CONNECTIONS AND**  
**TRUSS TO TOP PLATE TO STUD CONNECTIONS**



**FIGURE 307F  
ROOF SHEATHING LAYOUT  
AND ENDWALL ROOF BRACING**

**307.4 ROOF SHEATHING**

**307.4.1 Roof Sheathing Thickness:** Roof sheathing shall be a minimum of 15/32-inch Exposure 1 wood structural panels installed in accordance with Figure 307F. Long dimension shall be perpendicular to framing and end joints shall be staggered.

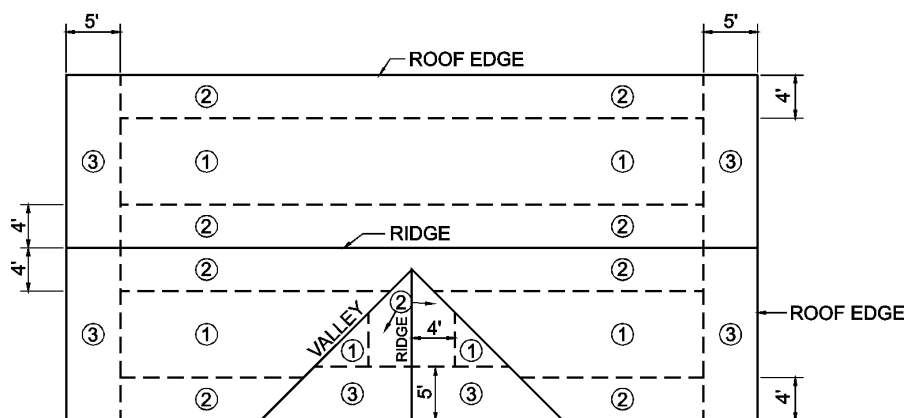
EXCEPTION: Where stronger or weaker roof diaphragms are required (See 307.5).

**307.4.2 Roof Sheathing Spans:** Roof framing shall be spaced such that the sheathing spans do not exceed those specified in Table 2307.6B of the Standard Building Code. In no case shall spacing exceed span ratings shown on sheathing panels.

**307.4.3 Sheathing Fastenings:** Sheathing shall be fastened to roof framing with 8d common or 8d hot dipped galvanized box nails at 6 inches o.c. at edges and 6 inches o.c. at intermediate framing

EXCEPTIONS: (See Figure 307G for nailing zones).

1. Use 8d ring-shank nails for all fastening in nailing zone 3 for 110 mph design wind speeds and where Group III species framing lumber is used for 100 mph design wind speeds.
2. Space fasteners 4 inches o.c. minimum at gable endwall or gable truss.
3. Fastener spacing at intermediate supports in nailing zone 1 may be 12 inches o.c. for 90 mph design wind speeds and where Group II species framing lumber is used for 100 mph design wind speeds.
4. Where diaphragm requirements necessitate a closer nail spacing.



**FIGURE 307G  
ROOF SHEATHING NAILING ZONES**

**307.5 ROOF DIAPHRAGM**

**307.5.1** Roof sheathing and fasteners shall be capable of resisting the total shear loads specified in Table 307H1 and 307H2 for the applicable distance between shear walls. Shear capacities shall be based on the spacing of the roof framing members, sheathing material, sheathing thickness, nail size and nail spacing as specified in Table 304C1 and Table 304C2.

**307.5.2** Nailing pattern shall not be less than required by 307.4.3.

**307.5.3** Where roof diaphragms are not required to be blocked, continuous ridge vents may be used.

**TABLE 307H1**  
**ROOF DIAPHRAGM REQUIREMENTS AT SIDEWALLS**  
(Wind Parallel to Sidewalls)

Maximum Distance Between Shearwalls	90 mph	100 mph	110 mph
	Shear Capacity of Sheathing Material (plf) <sup>1</sup>		
1W-4W	120	150	180

W = Building Width

1. The values in the table above assume an 8 ft. wall height. When using a wall height of 10 ft., the required shear capacity shall be increased by 25%.

**TABLE 307H2**  
**ROOF DIAPHRAGM REQUIREMENTS AT ENDWALLS**  
(Wind Parallel to Endwalls)

Maximum Distance Between Shearwalls	90 mph	100 mph	110 mph
	Shear Capacity of Sheathing Material (plf) <sup>1, 2</sup>		
W	55	70	85
2W	105	125	155
3W	150	185	220
4W	195	240	290

W = Building Width

1. The values in the table above assume an 8 ft. wall height. When using a wall height of 10 ft., the required shear capacity shall be increased by 25%.

2. For single story buildings, values for roofs may be multiplied by 0.82 to account for lower wind forces at lower roof heights.

**308 OPEN STRUCTURES****308.1 GENERAL**

There are three general types of open structures contained in this standard (See 102.1(6) for graphic description):

- Unenclosed attached (3 sides open)
- Unenclosed portions of building (2 sides open)
- Open unattached (all sides open)

**308.2 COLUMNS**

**308.2.1** The requirements for columns have been keyed to the bending stress ( $F_b$ ) for normal duration of load. Single member  $F_b$  values for some common species can be found in Table 308A.

**TABLE 308A  
SINGLE MEMBER  $F_b$  VALUES FOR COLUMNS**

COMMON SPECIES AND GRADES <sup>1</sup> USED FOR COLUMNS				
Lumber Species		Grade & Size		$F_b$ <sup>2</sup>
DOUGLAS FIR-LARCH	19%	#2	4X4	1450
		#2 P&T	6x6	700
			8" Poles	2450
			10" Poles	2450
HEM-FIR	19%	#2	4x4	1150
		#2 P&T	6x6	525
SOUTHERN PINE	19%	#2	4x4	1400
		#2 SR	6x6	1100
			8" Poles	2400
			10" Poles	2400
SPRUCE-PINE-FIR	19%	#2	4x4	1000
		#2 P&T	6x6	500

1. Values for these and other species can be found in the ANSI/AF&PA National Design Specification® (NDS®) for Wood Construction.

2. These  $F_b$  values are for single member use.

**308.2.2 Columns Supporting Unenclosed Attached Structures:** Minimum requirements for columns supporting unenclosed attached structures are shown in Table 308B.

**TABLE 308B  
MINIMUM  $F_b$  FOR COLUMNS SUPPORTING  
UNENCLOSED ATTACHED STRUCTURES**

Structure Width	Column Spacing	90 mph		100 mph		110 mph	
		Size	$F_b$ (psi)	Size	$F_b$ (psi)	Size	$F_b$ (psi)
4'	2' o.c.	4x4	1000	4x4	1150	4x4	1400
	3' o.c.	6x6	500	6x6	700	6x6	700
	4' o.c.	6x6	1100	6x6	1100	6x6	1100
	6' o.c.	8" Pole	2400	8" Pole	2400	8" Pole	2400
	8' o.c.	8" Pole	2400	8" Pole	2400	10" Pole	2400
	10' o.c.	10" Pole	2400	10" Pole	2400	10" Pole	2400
	12' o.c.	10" Pole	2400	—	—	—	—
16'	2' o.c.	6x6	500	6x6	700	6x6	700
	3' o.c.	6x6	1100	6x6	1100	8" Pole	2400
	4' o.c.	8" Pole	2400	8" Pole	2400	8" Pole	2400
	6' o.c.	8" Pole	2400	10" Pole	2400	10" Pole	2400
	8' o.c.	10" Pole	2400	—	—	—	—
40'	2' o.c.	6x6	1100	6x6	1100	8" Pole	2400
	3' o.c.	8" Pole	2400	8" Pole	2400	8" Pole	2400
	4' o.c.	8" Pole	2400	10" Pole	2400	10" Pole	2400

**308.2.3 Columns Supporting Unenclosed Portions of Building:** Minimum requirements for columns supporting unenclosed portions of the main structure are shown in Table 308C.

**TABLE 308C  
MINIMUM  $F_b$  FOR COLUMNS SUPPORTING  
UNENCLOSED PORTIONS OF BUILDING**

Structure Width	Column Spacing	90 mph		100 mph		110 mph	
		Size	$F_b$ (psi)	Size	$F_b$ (psi)	Size	$F_b$ (psi)
4'	2' o.c.	4x4	1000	4x4	1000	4x4	1000
	3' o.c.	4x4	1000	4x4	1150	4x4	1400
	4' o.c.	4x4	1400	6x6	500	6x6	700
	6' o.c.	6x6	700	6x6	1100	6x6	1100
	8' o.c.	6x6	1100	8" Pole	2400	8" Pole	2400
	10' o.c.	8" Pole	2400	8" Pole	2400	8" Pole	2400
	12' o.c.	8" Pole	2400	8" Pole	2400	10" Pole	2400
	14' o.c.	8" Pole	2400	10" Pole	2400	10" Pole	2400
	16' o.c.	10" Pole	2400	10" Pole	2400	—	—
	18' o.c.	10" Pole	2400	—	—	—	—
16'	2' o.c.	4x4	1000	4x4	1000	4x4	1400
	3' o.c.	6x6	500	6x6	525	6x6	700
	4' o.c.	6x6	700	6x6	1100	6x6	1100
	6' o.c.	8" Pole	2400	8" Pole	2400	8" Pole	2400
	8' o.c.	8" Pole	2400	8" Pole	2400	10" Pole	2400
	10' o.c.	10" Pole	2400	10" Pole	2400	10" Pole	2400
	12' o.c.	10" Pole	2400	—	—	—	—
	14' o.c.	10" Pole	2400	—	—	—	—
	16' o.c.	10" Pole	2400	—	—	—	—
	18' o.c.	10" Pole	2400	—	—	—	—
40'	2' o.c.	6x6	500	6x6	700	6x6	700
	3' o.c.	6x6	1100	6x6	1100	8" Pole	2400
	4' o.c.	8" Pole	2400	8" Pole	2400	8" Pole	2400
	6' o.c.	8" Pole	2400	10" Pole	2400	10" Pole	2400
	8' o.c.	10" Pole	2400	—	—	—	—

**308.2.4 Columns Supporting Open Unattached Structures:** Minimum requirements for columns supporting open unattached structures are shown in Table 308D.

**TABLE 308D  
MINIMUM  $F_b$  FOR COLUMNS SUPPORTING  
OPEN UNATTACHED STRUCTURES**

Structure Width	Column Spacing	90 mph		100 mph		110 mph	
		Size	$F_b$ (psi)	Size	$F_b$ (psi)	Size	$F_b$ (psi)
4'	2' o.c.	4x4	1000	4x4	1150	4x4	1450
	3' o.c.	6x6	500	6x6	700	6x6	700
	4' o.c.	6x6	1100	6x6	1100	8" Pole	2400
	6' o.c.	8" Pole	2400	8" Pole	2400	8" Pole	2400
	8' o.c.	8" Pole	2400	8" Pole	2400	10" Pole	2400
	10' o.c.	10" Pole	2400	10" Pole	2400	10" Pole	2400
16'	12' o.c.	10" Pole	2400	—	—	—	—
	2' o.c.	6x6	500	6x6	700	6x6	700
	3' o.c.	6x6	1100	8" Pole	2400	8" Pole	2400
	4' o.c.	8" Pole	2400	8" Pole	2400	8" Pole	2400
	6' o.c.	10" Pole	2400	10" Pole	2400	10" Pole	2400
40'	8' o.c.	10" Pole	2400	—	—	—	—
	2' o.c.	6x6	1100	6x6	1100	8" Pole	2400
	3' o.c.	8" Pole	2400	8" Pole	2400	8" Pole	2400
	4' o.c.	8" Pole	2400	10" Pole	2400	10" Pole	2400

### 308.3 COLUMN EMBEDMENT

**308.3.1** When resisting uplift and lateral loads, columns must be embedded not less than the minimum depths shown in Table 308E.

**TABLE 308E  
MINIMUM COLUMN EMBEDMENT DEPTHS**

Size	Roof Angle								
	5°			15°			25°		
	Backfill Material								
	Soil Only	Concrete 1' dia.	Concrete 2' dia.	Soil Only	Concrete 1' dia.	Concrete 2' dia.	Soil Only	Concrete 1' dia.	Concrete 2' dia.
Embedment Depth									
4x4	54"	36"	29"	67"	44"	36"	73"	49"	38"
6x6	56"	43"	35"	71"	55"	43"	78"	60"	48"
8" Pole	59"	52"	41"	76"	66"	53"	82"	71"	56"
10" Pole	61"	58"	46"	78"	73"	58"	84"	79"	64"

EXCEPTION: Embedment depths can be reduced 20 percent when a poured concrete floor is used in addition to the backfill materials given above.

**308.4 COLUMN CONNECTIONS**

**308.4.1** The columns shall be fastened to girders above and below in accordance with Section 2306 of the Standard Building Code. In addition, uplift connectors must be provided to resist the uplift loads shown in Table 308F.

**308.4.2** Uplift load requirements may be interpolated for intermediate building widths.

**TABLE 308F  
MINIMUM UPLIFT LOADS  
FOR COLUMN TO GIRDER CONNECTIONS**

Col. Spacing	90 mph					100 mph					110 mph				
	Building Width														
	4'	16'	24'	32'	40'	4'	16'	24'	32'	40'	4'	16'	24'	32'	40'
1' o.c.	79	184	255	327	398	107	250	348	446	543	138	324	450	577	704
2' o.c.	175	375	525	650	800	225	500	700	900	1100	275	650	900	1150	1425
3' o.c.	250	550	775	1000	1200	325	750	1050	1350	1625	425	975	1350	1750	2125
4' o.c.	325	750	1025	1325	1600	425	1000	1400	1800	2175	550	1300	1800	2325	2825
6' o.c.	475	1100	1550	1975	2400	650	1500	2100	2675	3275	825	1950	2700	3475	4225
8' o.c.	650	1475	2050	2625	3200	875	2000	2800	3575	—	1100	2600	3600	4625	—
10' o.c.	800	1850	2550	3275	—	1075	2500	3500	—	—	1400	3250	4500	—	—
12' o.c.	950	2225	3075	—	—	1300	3000	—	—	—	1675	3900	—	—	—
14' o.c.	1125	2575	—	—	—	1500	—	—	—	—	1950	—	—	—	—
16' o.c.	1275	—	—	—	—	1725	—	—	—	—	—	—	—	—	—
18' o.c.	1425	—	—	—	—	—	—	—	—	—	—	—	—	—	—

**308.5 GIRDERS**

Girders shall be designed in accordance with Section 2307.2 of the Standard Building Code and the American Forest and Paper Association's (AF&PA) Wood Structural Design Data using accepted roof dead and live load conditions.

**308.6 ROOF SYSTEM**

The roof system shall be designed in accordance with 307.

**309 EXTERIOR WALL VENEERS****309.1 INSTALLATION**

Exterior wall veneers shall be installed in accordance with Section 1403 of the Standard Building Code.